

RV/MARINE PRODUCT DATA SHEET

OEM: 255-2X3 (Strainers)
AFTERMARKET: 255-1X3 (Strainers)

APPLICATION

Fresh water pump debris strainer. Vacuum side only.

MATERIAL

Top Housing: Polypropylene
Bowl: Nylon
Gasket: EPDM
Screen: 50 Mesh T304 Stainless Steel

SPECIFICATIONS

Inlet Port: 1/2" NPSM [Male] or 1/2" Barb
Outlet Port: 1/2" NPSM [Male]
Max Temp: 120°F [48°C]
Max Pressure: Vacuum Side Only

APPROVALS

IAPMO [Meets NSF 61]

RELATED DOCUMENTS

RV Catalog: MS-030-138
Marine Catalog: MS-030-140
Installation Manual: 911-689
Applications Spec Guide: MS-020-005

SHIPPING

Net Weight: 0.12 Lbs
Approx. Lbs./Ctn.: 10 Lbs
Strainers in Carton: 96



Clean, clear economical strainers eliminate unnecessary repair by keeping debris and other particles out of the pump. Screws directly onto the pump head. Transparent design shows when it is time to clean the bowl. Easy disassembly, cleaning and reassembly.

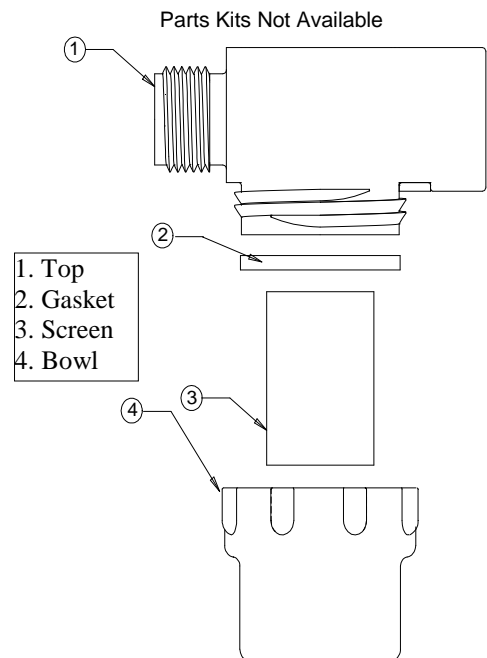

SHURflo reserves the right to update specifications, prices or make substitutions without notice.

SHURflo
52748 Park Six Court
Elkhart Indiana 46514-5427
Toll Free: (800) 854-3218
Fax: (574) 264-2169

SHURflo Europe, Middle East, Africa
Pentair Water Belgium bvba
B-2200 Herentals, Belgium
Phone: +32-14-283500
Fax: +32-14-283505

Visit our Website at www.shurflo.com

