

# HYDRO LIFE

THE BACTERIA FIGHTER • THE BACTERIA FIGHTER • THE BACTERIA FIGHTER

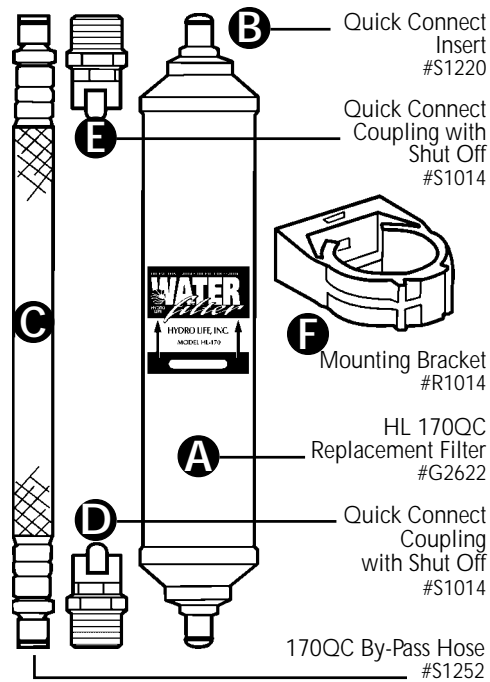

## INSTALLING MODEL HL-170, 171, 172 QC FILTER

1. Turn water off. To remove by-pass hose, push thumb release on quick connect couplings and carefully pull hose off water line.
2. To install filter be sure arrow on filter points in the direction the water will flow and carefully insert filter into mounting bracket (F).
3. Insert quick connect coupling (E) on outgoing water line onto top of filter, and click into place. Next, insert quick connect coupling (D) on incoming line, carefully onto bottom of filter and click into place. Push filter inward until bracket clamp snaps closed.
4. Slowly turn water on and check complete system for leaks. Allow water to flow for several minutes to flush the system.

## TO WINTERIZE & RE-INSTALL FILTER:

1. Shut off water supply. Place drip pan under filter, there will be some drainage from the filter and water line.
2. Release filter from mounting bracket (F) by placing thumbs on both sides of clamp, push in opposite directions (up and down), clamp will open.
3. For HL-170, 171, 172 QC, push thumb release on quick connect coupling (D) on incoming water line, and carefully pull water line off filter. Next, push thumb release on quick connect coupling (E) on other end of filter and carefully pull water line off filter (HL-170, 171, 172 TF Model, unscrew fittings).
4. To insert winterizing by-pass hose for HL-170, 171, 172 QC, push both ends of hose into quick connect couplings on water lines and click into place (HL-170, 171, 172 TF Model screw into place).
5. Do not allow filter to freeze. Store filter in a zip lock bag (provided) with water covering filter, in cool location not colder than 35° F.

## IMPORTANT:

- Replace filter annually to maintain high quality water.
- When winterizing do not allow anti-freeze to flow through filter (see above for complete instructions on winterizing your filter).
- Do not use where water is microbiologically unsafe or of unknown quality.
- If your RV or watercraft has not been used recently, turn water on and allow it to flow for several minutes to flush the system.

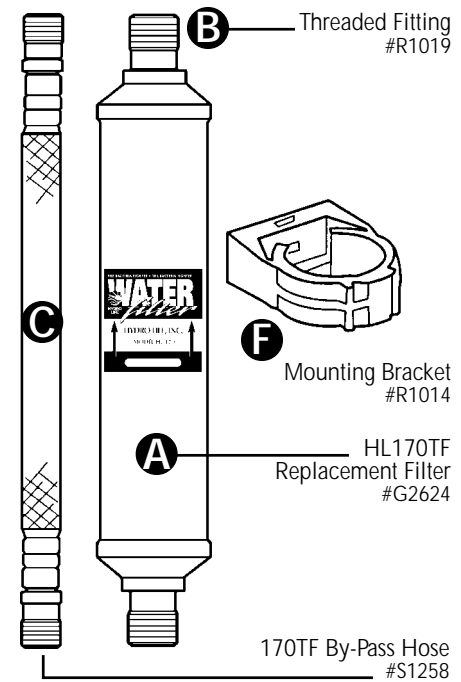

## INSTALLING MODEL HL-170, 171, 172 TF FILTER

1. Turn water off. To remove by-pass hose unscrew nuts on water line and pull hose off water line.
2. Carefully insert filter into mounting bracket (F), (arrow on filter should point in the direction the water will flow). Thread swivel nuts on water lines to top and bottom of filter, and push filter inward until bracket clamp snaps closed.
3. Slowly turn water on and check complete system for leaks. Allow water to flow for several minutes to flush the system.