

# Installation and Operation Instructions



## Models:

88-00-6500 (2¼" jacks)

88-00-6525 (2" jacks)

88-00-4500 (2¼" jacks)



Do not install the Flip in pre-drilled hole, unless it is a Fastway brand jack. Follow instructions to make sure hole is in the correct place for safe operation. Serious injury or damage could result.

### Tools Needed for Installation:

- 3/16" metal drill bit
- 1/2" metal drill bit
- Drill
- Wood block
- (1) 3/4" wrench
- (1) 9/16" wrench
- Measuring tape
- Pencil or scratch awl
- Center punch

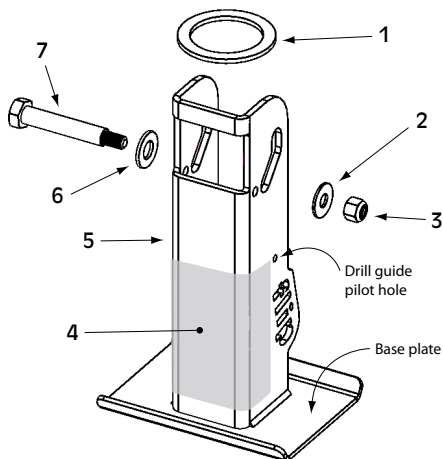

### Parts Breakdown

Fig. #	Part #	Description	Qty.
1	88-01-6200	Spacer ring (2" I.D.)	1
	88-01-6225	Spacer ring (1¾" I.D.)	
2	88-02-5138	3/8" washer	1
3	88-02-5122	3/8" nylock nut	1
4	BD088-WS	Warning sticker	1
5	88-01-6500 (6" Flip for 2¼" jack)	Flip automatic jack foot	1
	88-01-6525 (6" Flip for 2" jack)		
	88-01-4500 (4" Flip for 2¼" jack)		
6	90-04-9110	1/2" washer	1
7	88-02-5110	Shoulder bolt for 2¼" Flip	1
	88-02-5152	Shoulder bolt for 2" Flip	

## **WARNING**

- **Read entire instruction manual before using this product. Failure to do so can result in serious injury or property damage.**
- **Never exceed maximum tongue weight rating\* with your trailer uncoupled.**
- **Never exceed maximum 4,000 lb. lift capacity.\***
- **Do not use to support trailer parked on grade greater than 3% (1.72°).**
- **Chock tires on both sides while supporting trailer with jack foot.**
- **Do not support trailer with jack foot placed on unlevel ground or debris. Jack foot base plate must be in complete contact with ground.**
- **Support tongue weight with jack foot in vertical position only when attachment bolt is resting at bottom of guide slot.**
- **Replace worn or faded safety label immediately.**
- **Do not install 2¼" model on a 2" jack.**
- **Do not install the Flip in pre-drilled hole, unless it is a Fastway brand jack. Follow instructions to make sure hole is in the correct place for safe operation. Serious injury or damage could result.**

Maximum Tongue Weight Rating*	
Model	Max tongue wt.
88-00-6500	1,400
88-00-6525	1,400
88-00-4500	1,600

## **CAUTION**

- **Always use adequate personal protective equipment when installing.**
- **Wear safety glasses when installing.**
- **Avoid pinch points between jack extension, spacer ring, jack, and trailer frame when retracting jack.**

### \*Maximum Tongue Weight vs. Maximum Lift Capacity

Maximum tongue weight refers to a trailer chocked but uncoupled. Maximum lift capacity is with tow vehicle securely coupled, parking brake on, and trailer chocked. This applies when someone is using the jack to lift both the trailer tongue and tow vehicle to put the spring arms of a weight distribution hitch in place.

# Installation Instructions

## STEP 1

**Locate trailer on a flat level surface**, such as a driveway or parking lot. Chock both sides of the trailer, and set tow vehicle parking brake. Keep trailer coupled to tow vehicle, or place jack stands under trailer tongue to support trailer without the use of the tongue jack. Disconnect trailer plug, safety chains, and safety breakaway cable from the tow vehicle and move them out of the way.

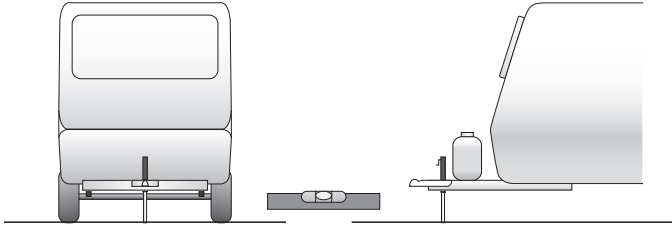

*Install Flip jack foot with trailer parked on level ground both side-to-side and front-to-back.*



**Never exceed maximum tongue weight rating.**

**Never exceed max 4,000 lb. lift capacity.**

**Do not install 2¼ model on a 2" jack.**

## STEP 2

**Retract your jack all the way and measure how much of the inner tube is sticking out below the outer tube.** If it is more than 2-1/4" the Flip will not flip up under the frame properly.

If you have more space than 2-1/4" you have two options.

1. Cut off some of the bottom of the **inner** jack tube. (See Step 3, Option 1)
2. Add extra spacer washers. Each spacer washer is 1/8" thick. One (1) is supplied with your Flip.

You will need enough to make up the difference between what you measured to be sticking out beyond the outer tube and 2-1/4". For example: if that measurement is 2-5/8" you will need to use four (4) spacer washers total.

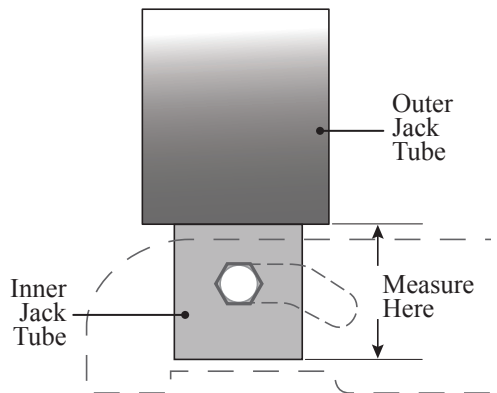

## **STEP 3**

### **Options for jacks with pre-existing holes in inner jack tube.**

Non-Fastway brand jacks with a pre-drilled hole may interfere with the Flip installation or operation. DO NOT install Flip in a pre-existing hole unless it is a Fastway brand jack. Ignoring this may cause Flip malfunction and collapse of the Flip when loaded with tongue weight.

Please **read the following three options** before drilling the install hole for your Flip jack foot.

**If your jack does NOT have a pre-existing hole at the bottom of the inner jack tube, skip to Step 4a.**



**Always wear adequate personal protection equipment while installing.  
Wear safety glasses.**

#### **Option 1: The first option, and best solution, is to cut 1/2" or more off the bottom of the inner tube.**

Use a pipe cutter if possible, or a cutting wheel or hack saw. Make the bottom as square and even as possible. Some grinding/filing might be necessary to make a good even bottom edge for the drill guide. By removing about 1/2" from the bottom, the drill guide will then drill the hole with more material in-between the two holes. Although more work, this is the best solution.

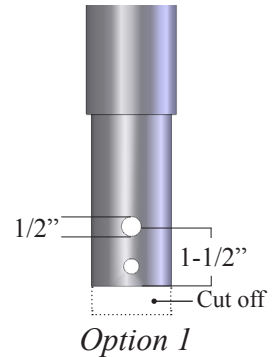

If you have already drilled the hole as in options 2 or 3, but decide you don't like it, use option 1. Cut off at least 1/2" or more as needed.



**Watch a complete step-by-step Flip install at:  
[YouTube.com/FastwayTrailer](https://www.youtube.com/FastwayTrailer)**

### Option 2: Drill the hole in the normal location.

There may be very little material between the two holes, if any. This is okay, even if the holes interfere slightly. The Flip will still function normally. It is also okay if the thin bit of material between the holes deforms, or even breaks apart. There will still be sufficient material on the sides to hold the bolt and lift the Flip.

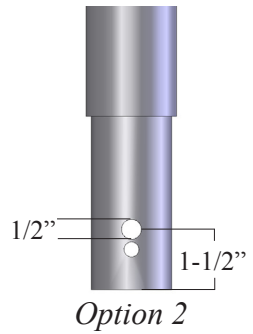

**Option 3: Drill a 3/8" instead of 1/2" hole,** and use a 3/8" x 3" grade 5 bolt. This will leave more material between the holes. This is a good solution for lower tongue weights. For higher tongue weights, consider option 1 or option 2.



Grade 5 bolts are marked with 3 lines on the head.

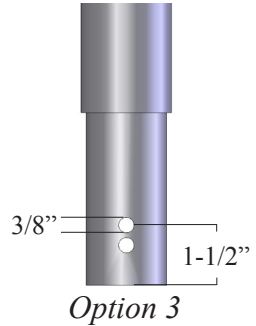

## STEP 4a - Locating hole in square jack

If you are installing the Flip jack foot on a round jack, skip to [step 4b](#).

If you are installing the Flip jack foot on a square jack you cannot use the guide holes pre-drilled in the Flip to locate the pilot holes as you can with a round jack. The pilot hole must be drilled free hand, or by removing the jack from the trailer and using a drill press.

Looking at the driver's side face of the jack, measure up from the bottom of the inner jack tube 1-1/2" and scratch or draw a mark.

Measure 1/2 the distance between the front and back faces of the tube and scratch or draw a line that crosses the first. This should be at 7/8" on a 2" jack, or 1" from both the front and back on a 2-1/4" square jack with a 2" inner jack tube. Repeat this process for the passenger side.

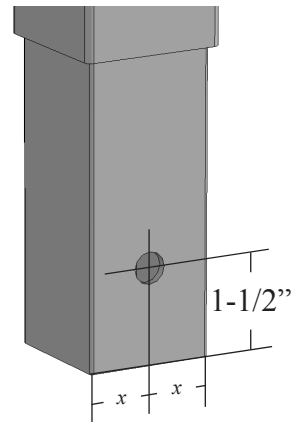

Mark with center punch on both sides. Drill 3/16" pilot hole, then 1/2" install hole.

Use a center punch to make a mark at these locations on both sides of the jack. Drill two 3/16” pilot holes on both sides using these punch marks as a guide to start the hole.

Switch drill bits, and use a 1/2” bit to enlarge both pilot holes. Pass the drill bit completely through the jack to make sure the 1/2” installation bolt will fit smoothly.

Go on to **Step 5** to continue the Flip installation.

### **STEP 4b** - Locating hole in round jack

Retract the tongue jack far enough that you can fit a wood block and Fastway Flip jack foot under the inner-jack tube. Place the wood block on the ground, and place the jack foot on top, face down with the base plate toward the back of the trailer.

Slowly extend the jack tube into the Flip until it rests on the jack foot and wood block (1), and so that the locating plate is pushed up tightly against the front wall of the inner jack tube (2).

The drill guide holes should be perpendicular to the centerline of the trailer and jack tube. They should be 1-1/2” from the bottom of the tube, and centered on the tube.

Extend the jack until the weight resting on the Flip jack foot holds it securely in place so that it will not move while the guide holes are being drilled.

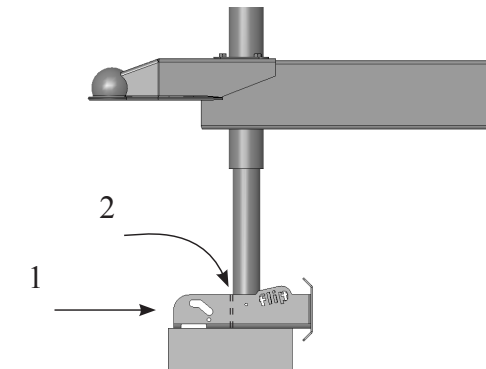

*Push jack foot backward (1) so that inner jack tube is tight to locating plate (2).*

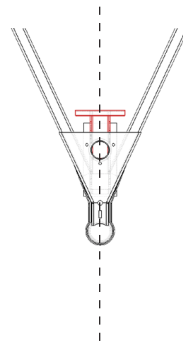

*Make sure jack foot is placed parallel to the trailer before drilling guide holes.*

Use the 3/16" bit and drill a pilot hole on each side of the jack tube using the drill guide pilot holes on both sides of the jack foot as guides. Retract the jack to a comfortable drilling height, and remove the Flip jack foot and the wood block.

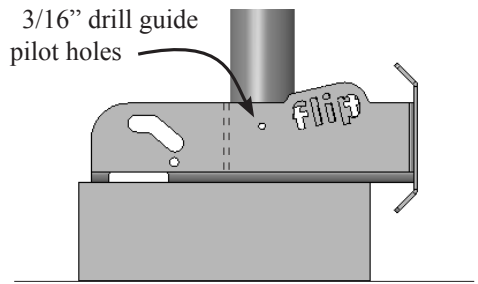

*Use drill guide pilot hole to drill 3/16" pilot holes on each side of inner jack tube.*

Use the 1/2" drill bit to enlarge a pilot hole. Once the tube wall has been penetrated, ream out the hole slightly to de-burr it and open it up. Switch sides, and drill and ream the second hole. Pass the drill bit all the way through the inner jack tube to make sure there is a clean path for the bolt all the way through the tube.

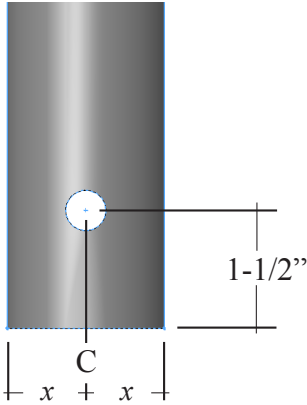

*Enlarge with 1/2" drill bit.*

**STEP 5**

If drilling the holes leaves a burr or lip, use a file or grinder to smooth the edge so that the pivoting operation of the Flip jack foot is not disrupted.

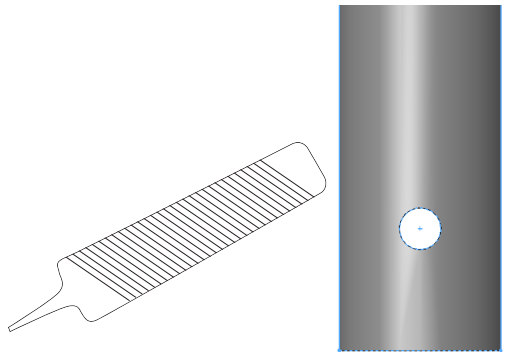

## **STEP 6**

**On a round jack the spacer ring must be in place or the jack foot will not “flip” up completely. A square jack does not need a spacer ring for the Flip jack foot to operate correctly.**

**Slide the spacer ring up the inner jack tube and hold it up while you position the jack foot to bolt it on.** Position the jack foot around the inner jack tube so that the slot at the top lines up with the 1/2” holes just drilled in the jack tube. You may need to retract the jack.

Slide the 1/2” washer onto the 1/2” bolt, and slide the bolt through the slot in the top of the jack foot and the 1/2” hole in the inner jack tube. Slide the smaller 3/8” washer over the threaded end of the bolt, and then thread on the Nylock nut. Tighten the nut securely and then check to make sure the Flip jack foot can swing freely up and down.

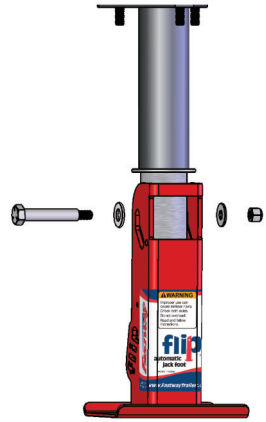

**A small amount of lubricant** helps the Flip rotate more freely. Do not use petroleum based grease. Use a wax-based bicycle chain lubricant or a spray-on, silicone-based lubricant that naturally repels dust and dirt. Apply lubricant to any surface area that rubs against another during Flip foot operation, such as the top and bottom of the 2” ring, top of the Flip foot, and inner edges of the bolt-guide slot. Wipe off any excess.

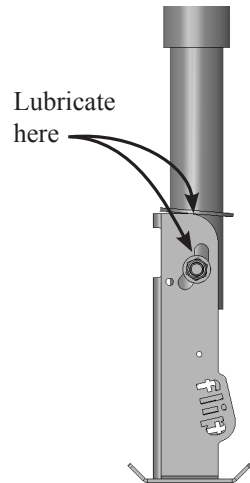

*Finished assembly of Flip jack foot on round jack.*



## Instructions for Use



**Do not use to support trailer parked on grade greater than 3% (1.72°).**

**Do not support trailer with jack foot resting on unlevel ground or debris.**

**Jack foot base plate must be in complete contact with ground.**

### **STEP 7**

#### **When uncoupling your trailer:**

**Make sure that the trailer is parked on relatively level ground.** Most improved campsites are fine. Pay special attention to the site when dry camping to make sure the slope is not more than a 3% grade ( 1.72° ) either side-to-side or front-to-back.

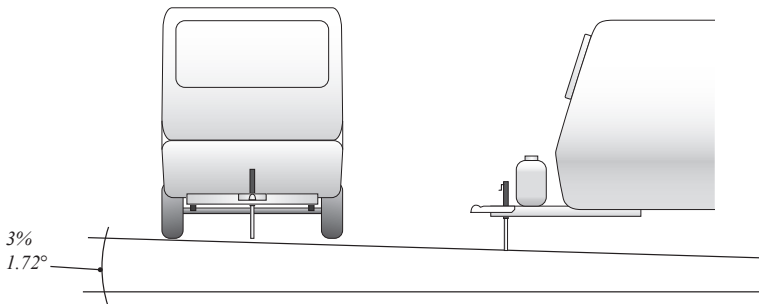

*Do not use Flip with trailer parked on a slope steeper than a 3% grade, or 1.72 degrees.*

Also make sure that the spot where the jack foot will rest is as level as possible, and free from debris like sticks or stones that might keep the jack foot from being completely supported.

Chock the wheels on both sides of the trailer securely. Disconnect trailer plug, safety chains, and breakaway cable from the tow vehicle. Uncouple the coupler, and extend the jack to raise the coupler off the ball.

If using a weight distributing hitch, you may use the jack foot to raise both the tow vehicle and trailer to make it easier to disconnect the hitch. Make sure to not exceed maximum lift capacity\* (See top of Page 10). Once the spring arms are disengaged, lower the trailer and tow vehicle back to a point where the tow vehicle is supporting all of the trailer's tongue weight. Uncouple the coupler, and extend the jack to raise the coupler off the ball.

**\*NOTE: Maximum Tongue Weight vs. Maximum Lift Capacity**

Maximum tongue weight refers to a trailer chocked but uncoupled. Maximum lift capacity is with tow vehicle securely coupled, parking brake on, and trailer chocked. This applies when someone is using the jack to lift both the trailer and tow vehicle to put spring arms of a weight distribution hitch in place.



**Support tongue weight with jack foot in vertical position only when attachment bolt is resting at bottom of guide slot.**

**STEP 8**

The Flip jack foot is designed to straighten automatically as more weight is applied. At times it may be helpful to move it forward slightly with your foot to make sure it sits directly below the jack so that the jack tube rests correctly at the bottom of the bolt slot, and against the front of the jack foot or on top of the support/locating plate.

If the full tongue weight is placed on the jack with the jack foot out of position, the inner jack tube can bend, resulting in improper function of the jack or jack foot. It may also damage the jack foot or trailer.

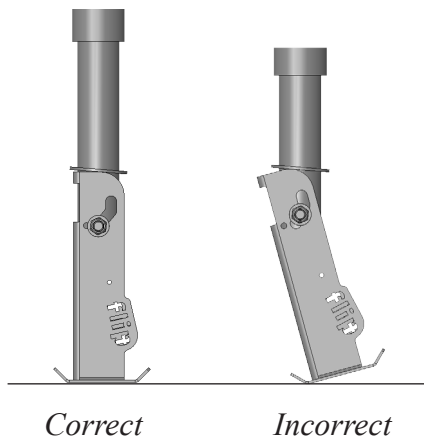

**STEP 9**

If you must drop the trailer in a place where there is not enough clearance below the jack for the Flip jack foot to pivot down properly, the jack may be extended with the jack foot in a horizontal position. If desired, a small block of wood placed directly under the inner jack tube will help protect the Flip jack foot from scratches.

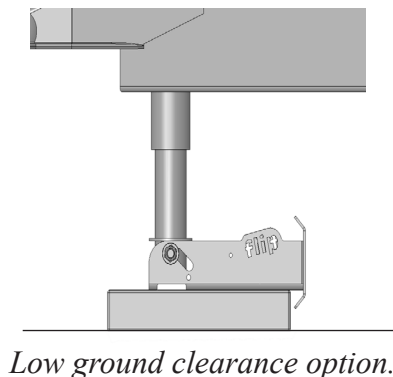

*Low ground clearance option.*

## **STEP 10**

### **To couple your trailer:**

Back the hitch ball under the coupler. Retract the tongue jack until the coupler rests on the hitch ball. Lock the coupler. If you are using a weight distributing hitch, extend the jack and tension the weight distribution bars.

Retract the jack completely until the flip rotates up and out of the way for towing. Do not force the jack handle after the jack has reached the top of travel. Rotate it back slightly if necessary for towing.

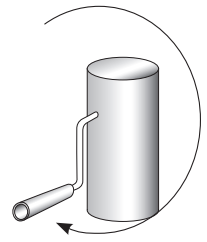
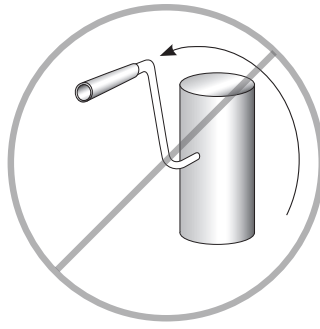

*Don't force jack. Rotate back slightly if necessary.*

### **TOP-WIND JACK CAUTION:**

When traveling on very rough washboard roads for an extended period of time, the vibration can cause the jack to unwind slightly, causing the jack foot to drop out of towing position.

**SOLUTION:** If you must tow over this type of road we recommend that the Flip jack foot be secured in a way that prevents the jack from unwinding. This can be done by inserting a 1/4" x 2-1/2" pin through the locking hole with the Flip jack foot retracted completely. Other temporary solutions may include securing the jack handle so that it cannot rotate, or holding the Flip foot up with an elastic (Bungee®) cord.

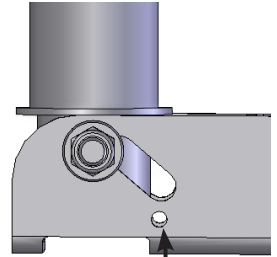

Insert pin here.

### **Limited One Year Warranty**

*Progress Mfg. Inc. warrants, to the original purchaser, this product against defects in materials and workmanship for a period of one year from date of purchase. This warranty does not cover damage due to normal wear and tear, misuse, neglect, abuse, or product finish. Progress Mfg. Inc. reserves the right to repair or replace the defective part(s) at their discretion. Replacement of product or refund constitutes the fulfillment of all liabilities of Progress Mfg. Inc. under this warranty. For questions about warranty coverage and warranty authorization, please call (877) 523-9103. If warranty repair or replacement is approved, send the entire product and proof of purchase, shipping pre-paid, to: Progress Mfg. Inc., 353 South 1100 West, Provo, UT 84601*

**Submit your warranty registration online at [FastwayTrailer.com](http://FastwayTrailer.com)**

**A Product of Progress Mfg. Inc.**

# Other Great Fastway Products!

The Fastway Zip™ breakaway cable's coiled design keeps your cable from dragging!

**Zip™**  
Trailer Breakaway  
Cable & Switch



Fastest and easiest tandem axle wheel chock ever!

**ONEstep™**  
tandem axle wheel chock

**Easy as...**

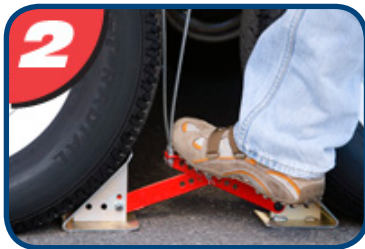
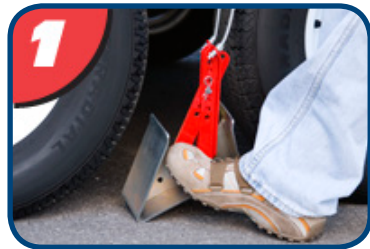

Fastway Trailer Products  
353 South 1100 West, Provo, UT 84601  
(877) 523-9103

**[FastwayTrailer.com](http://FastwayTrailer.com)**

© 2009 - 2015 Copyright Progress Mfg. Inc., All rights reserved.

FLIN0915

*All products patent pending.*