

WF-8900-REP Series

Converter Replacement Kit

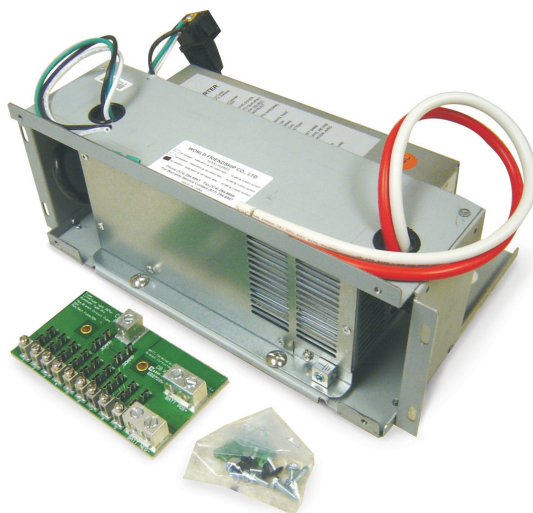

THE HEARTBEAT OF TODAY'S RVs

Distributed in the U.S.A. and Canada by
ARTERRA DISTRIBUTION

(877) 294-8997

Warranty: warranty@wfcoelectronics.com

Fax (574) 294-8698

www.wfcoelectronics.com



Power PROs Technical Support
(877) 294-8997

TABLE OF CONTENTS

SAFETY INFORMATION	3
KIT FEATURES	3
PERFORMANCE FEATURES	4
INSTALLATION INSTRUCTIONS	
Tools Needed	4
Step-by-Step Instructions	4
DC Fuse Board	5
TROUBLESHOOTING INSTRUCTIONS	6
GENERAL INFORMATION	
Reverse Battery Protection	6
Automatic Cooling Fan	7
Over-Temperature Protection	7
Electronic Current Limiting	7
Short-Circuit Protection	7
CIRCUIT PROTECTION	
DC Fuses	7
OPERATIONAL FEATURES	
Three-Stage Smart Charging	8
Absorption Mode	9
Bulk Mode	9
Float Mode	9
Converter Output Voltage	10
Reverse Polarity Fuses	10
Troubleshooting Flow Chart	11
GENERAL COMPLIANCE INFORMATION	
Agency Listings	11
SPECIFICATIONS	12
WARRANTY INFORMATION	13





⚠ WARNING
RISK OF ELECTRICAL SHOCK Disconnect or isolate all power supplies before making electrical connections. More than one disconnection or isolation may be required to completely de-energize equipment. Contact with components carrying hazardous voltage can cause electric shock and may result in severe personal injury or death.
NOTICE
All wiring must conform to local, national, and regional regulations. Use copper conductors only for all wire connections. Do not exceed the electrical ratings for the WF-9800 Series Converter-Charger as this may cause equipment failure and/or electrical shock which may result in severe personal injury or death.
⚠ CAUTION
INSTALLATION AND SERVICING This product should be installed and serviced by a certified or licensed electrician familiar with applicable safety codes and installation requirements. Failure to observe this precaution could result in electrical shock or bodily injury. Consult your servicing dealer before attempting any work on this product.
⚠ WARNING
SPARK HAZZARD This unit employs components that can produce arcs or sparks. To prevent fire or explosion, do not install in compartments containing batteries or flammable materials (LP gas). This product is NOT ignition protected.
⚠ CAUTION
DO NOT OBSTRUCT VENTILLATION To prevent fire, DO NOT cover or obstruct enclosure ventilation openings. DO NOT mount unit in a zero-clearance compartment as overheating may result. For continued protection against risk of fire or electric shock, replace faulty DC fuses and AC breakers with ones of the same type and ratings as are installed.
⚠ WARNING
BATTERY SYSTEM Use converter only on appropriate battery systems. Other usage may cause personal injury and damage. Consult all battery manufacturer's recommendations for additional safety information before use.

GENERAL INFORMATION

WF-8900-REP Kit Features

The WF-8900-REP Converter Replacement Kit allows easy upgrade of existing power centers. Technicians can easily remove the lower section of certain power center brands and slide in the WF-8900-REP unit. This exchange upgrades the old single stage charger to a high performance three-stage charging powerhouse.

The WF-8900-REP Kit contains all the necessary parts needed for the conversion:

- Metal mounting frame with preinstalled WF-9800 Series deck mount converter/charger
- Nine-circuit fuse panel with two preinstalled reverse polarity fuses
- All required mounting fasteners



OPERATIONAL FEATURES

WF-8900-REP Performance Features

The WF-8900-REP Converter Replacement Kit provides all of WFCO's performance standards:

- Quiet Operation
- Filtered Power
- Overload Protection
- Short Circuit Protection
- FCC Class B Approval

INSTALLATION INSTRUCTIONS

Installing the WF-8900-REP Kit

Tools Needed for Assembly:

- Safety Glasses
- Large and Small Straight Blade Screwdriver
- #2 Phillips Screwdriver
- #2 Square Drive Screwdriver
- Pliers
- 1/4" Nutdriver
- 5/16" Nutdriver

Step-By-Step Installation:

Before beginning installation, Make sure no AC power is coming into the RV from either the Shore Power cord or an on-board generator. Remove and set aside the Reverse Polarity Fuses located on the fuse board to disconnect the converter section from the rest of the RV's DC power.

WARNING

RISK OF ELECTRICAL SHOCK

Disconnect or isolate all power supplies before making electrical connections. More than one disconnection or isolation may be required to completely de-energize equipment. Contact with components carrying hazardous voltage can cause electric shock and may result in severe personal injury or death.

In order to install the WF-8900-REP Kit, you must first remove the existing converter section in your power center. This kit can be used on several different products. Your power center may differ slightly in the removal process.

Removing the original converter section:

Removal of the original power center is divided into 3 segments:

- Removing the AC (110 volt) side of the converter
- Removing the DC (12 volt) side of the converter
- Removing the converter MBA (Main Board Assembly)

Removing the AC (110 volt) side of the converter:

1. Drop the front door down and turn off 30amp main breaker.
2. Remove all screws holding the front door assembly on.
3. Remove (2) screws holding the metal plate that covers the AC breakers.
4. Remove the converter neutral wire (white wire) from the neutral bus bar.
5. Remove the converter ground wire (green wire) from the ground bus bar. **Note:** some converters may not have ground wire attached to the bus bar.
6. Remove the converter hot wire (black wire) from the breaker provided for the converter.
Note: sometimes removing the breaker from the stab bar may make this step easier.

Removing the DC (12 volt) side of the converter:

7. Record the fuse locations and wire locations off the old fuse board.
8. Remove all the output circuit wires from the fuse board.
9. Remove the (2) screws that hold the fuse board to the converter mounting bracket.
10. Turn the fuse board over to the back side and remove the red wire, white wire and blue wire from the fuse board.

Removing the converter MBA:

11. Remove the (4) screws holding the converter (MBA) frame to the housing.
12. Slide the converter MBA and frame out of the housing.

Note: The new WF-8900-REP comes with a new fuse board and hardware package.

Installation of the WF-8900-REP is divided into 3 segments:

- Installing new converter (MBA) into housing.
- Installing the DC (12 volt) side of the converter
- Installing the AC (110 volt) side of the converter

Installing new converter (MBA) into housing:

1. Position the new converter and frame in front of housing and remove the (2) screws hold the converter to the frame (this make routing the wires easier).
2. Carefully install the frame and converter into the housing and route wires from the converter through the holes in the frame and the housing.
3. Once all wires are routed correctly replace the (2) screws that hold the converter to the frame.
4. Attach the frame to the housing using the (4) screws provided.

The WF-8900-REP DC Fuse Board

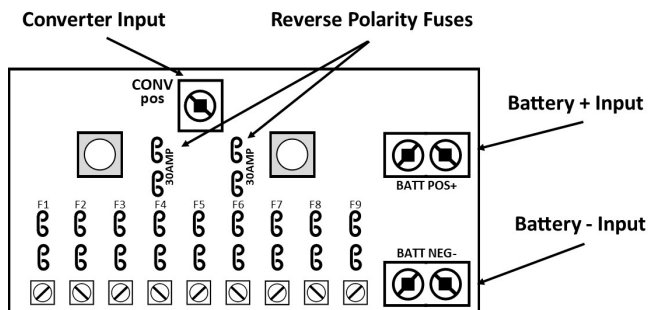

DC Output Terminals



Installing the DC (12 volt) side of the converter. Refer to Figure 1 Above:

5. Route the red wire from the converter up behind the mounting bracket for the fuse board and connect it to the lug on the fuse board marked CONV POS.
6. Route the white wire from the converter to the fuse board and connect it to the lug on the fuse board marked BATT NEG-.
7. Connect your wire coming from the battery positive to the lug on the fuse board marked BATTERY POS+.
8. Connect your wire coming from the battery negative to the lug on the fuse board marked BATT NEG-. NOTE: In some applications where the items in the RV are not grounded to frame you may have to run an 8 AWG wire from the BATT NEG- lug on the fuse board out the back of the housing and connect it to an additional bus bar (customer will have to purchase). Then connect the wire from the battery negative and any negatives from the DC items to this bus bar.
9. Attach the fuse board to the mounting bracket using the (2) screws provided.
10. Make sure you have the (2) 30amp reverse polarity fuses in place and connect all the DC output wire (as recorded) to the fuse board along with the correct fuse locations.

Installing the AC (110 volt) side of the converter:

11. Connect the neutral (white wire) from the converter to the neutral bus bar.
12. Connect the converter hot wire (black wire) from the converter to the breaker for the converter.
13. Connect the ground wire (green wire) from the converter to the ground bus bar.
14. Replace AC cover plate using the (2) screws provided.
15. Replace the door assembly using the screws provided
16. Turn all breaker on and apply 110volt power to the RV. Test for operation.

TROUBLESHOOTING INSTRUCTIONS

Troubleshooting the WF-8900-REP Series

Refer to the WF-9800 Series Troubleshooting Guide for the WF-9800 Series Deck Mount found on page 11 of this manual.

GENERAL INFORMATION

WF-9800 Series Converter-Charger Safety Features

Reverse Battery Protection

The WF-9800 Series Converter-Chargers will charge the 12-volt house battery if installed. A battery does not have to be installed for WF-9800 Series Converter-Chargers operation. When a battery is installed, two reverse polarity fuses are installed to protect the converter circuitry. The fuses are located on the rear panel of the enclosure near the AC power cord (refer to Figure 2 below). This feature prevents permanent damage to the converter from a battery connected into the circuit backwards. In addition to protecting the converter-charger, the reverse polarity fuses are the main connection between the converter-charger and the DC fuse board of a distribution center.



Automatic Cooling Fan

The cooling fan in the WF-9800 Series Converter-Chargers is incremental and is controlled by the current drawn out of the converter to the applied load. The on-board microprocessor increases fan speed as the total load increases and decreases fan speed as the load decreases.

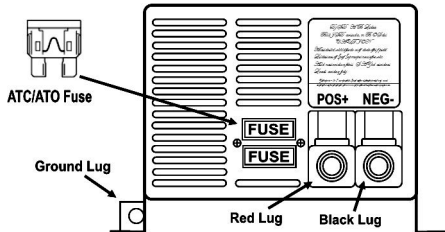

Figure 2

Unlike traditional temperature-controlled fans, the load-controlled fan provides better component cooling by avoiding temperature spikes which can lead to premature component failure.

Over-Temperature Protection

If the internal temperature of the converter exceeds a critical point, it will shut down. This protects the unit from excessive heat that may damage sensitive components. The unit will restart once the temperature inside has dropped.

Electronic Current Limiting

In the event that the output current exceeds the maximum rating for the WF-9800 Series Converter-Charger, the output current will remain constant, but the output voltage will begin to drop. If this occurs, the unit will recover once loads are reduced.

Short-Circuit Protection

Should a short circuit occur in the RV, the WF-9800 Series Converter-Charger will drop the voltage output to zero volts. If the short-circuit condition is removed and no other fault conditions are detected, the converter will resume normal operation. However, short-circuit conditions are dangerous, and an RV will require inspection by a qualified service technician.

CIRCUIT PROTECTION

WF-9800 Series Converter-Charger Fuses

DC Fuses (12 Volts)

The DC fuse receptacle on the rear panel of the WF-9800 Series Converter-Charger has space for 1 (one) or 2 (two) Reverse Battery Protection fuses (see Figure 2 above). These fuses should be replaced with ATC or ATO automotive type fuses, such as Littelfuse type 257 or Bussmann type ATC. Each converter model requires a different Amperage value fuse as follows:

WF-9835 – (1) 40A

WF-9845 – (2) 30A

WF-9855 – (2) 35A



OPERATIONAL FEATURES

Converter Operation Modes



Three-Stage Smart Charging

The three-stage “smart” charger continuously measures the battery voltage output and regulates the amount of charge using three modes of operation; Absorption, Bulk, and Float.

3-Stage Charging

WFCO converters of every style have become the favored brand for power conversion and electric distribution in the RV industry. They provide RV owners with an efficient and cost-effective method to use an AC power source and provide power to DC components inside the RV, while charging accessory batteries at the same time.

Smart Engineering: Three Stage Charging is Better

WFCO’s automatic three-stage converters handle every charging need for the RV while extending the battery’s life. Well-maintained batteries should never need more than two-stage (Normal and Trickle) charging. Our third stage (Bulk) is provided for the rare times a battery needs extra power for charging.

RVs are frequently sold with at least one 12 VDC accessory battery installed. This battery is normally a deep-cycle battery that has the ability to sustain a slower drain of power. RV owners find this useful when powering loads such as lights, radios, and refrigerators without being connected to AC power or running the motorhome engine. As soon as the RV is connected to AC power, the converter begins charging the battery as needed, while, at the same time, providing 12 VDC power to loads such as lights, radios, and refrigerators.

When the RV is connected to AC power, users frequently use the lights, refrigerators, fans, and other electronics as they would in their home. RV users also expect the battery to be fully charged when they want to disconnect from power and move the RV, or when they are dry camping and turn off their generator.

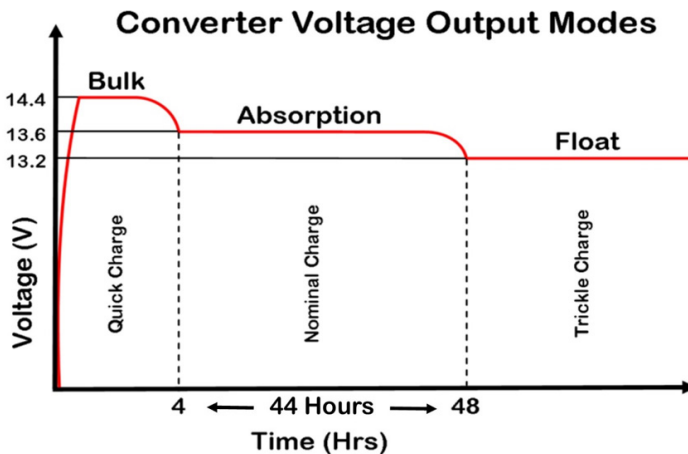

Figure 3



Absorption Mode:

This is the default, or normal operation, providing an output of 13.6 volts DC. Because RVs today are designed with converters sized to provide ample DC output power for all DC loads in normal usage, an RV will rarely require anything other than Absorption Mode.

When a WFCO converter is connected to a battery in Absorption Mode, power is available for charging that battery whenever the converter output is greater than the voltage level of the battery. If the battery is at or near fully charged, the current draw from the converter to the battery may be very small. On the other hand, if the battery were to be fully discharged, the current draw from the converter to the battery may be quite high.

Testing has shown that a completely discharged battery (11.9 VDC) connected to a WFCO converter in Absorption Mode with an output of 13.6 VDC and having a 20 Amp lighting load connected to the converter will charge the battery to its fully charged level of 12.7 VDC in fewer than three hours. Adding more DC loads will lessen the amount of current available and will lengthen the time required to charge the battery. Batteries with damaged cells will also require additional time to charge and may never reach a full charge voltage.

Because of the relationship between voltage and amperage, once the converter reaches its maximum rated operating current level, any increase in the DC load will start to decrease the voltage output level. When the output from the converter reaches a preset level, the converter will go into Bulk Mode.

Bulk Mode:

This is designed to charge a significantly discharged battery in a little less time than Absorption Mode. The microprocessor in WFCO converters continuously monitors the DC line voltage. When the microprocessor detects the preset voltage level, it will boost the converter voltage to 14.4 VDC. The increased voltage will help the battery charge faster, while still providing power to the DC appliances in the RV.

In Bulk Mode, it may not be possible to observe the 14.4 VDC output because of the voltage-current relationship. To measure the 14.4 VDC, reduce some DC loads while monitoring the voltage at the converter output. As the DC loads are removed, the voltage will begin to climb until 14.4 VDC (nominal) is shown on the meter.

As the battery continues to charge, the current drawn by the battery will gradually decrease. WFCO converters are designed to drop out of Bulk Mode when the total amperage draw from the converter reaches a preset point, indicating the battery is charged. If the amperage draw stays above the preset point, the converter will stay in Bulk Mode for a maximum of four hours. These features have been implemented to protect and extend the life of the battery.

Float Mode:

This is the third stage of converter operation. This mode is designed to provide a trickle charge to the battery. If the converter observes no significant variations in current draw for approximately 44 continuous hours, it will drop the output of the converter from 13.6 VDC to 13.2 VDC. This lower voltage will keep the battery charged while the RV is not in use. This also helps preserve the life of the battery, while keeping it charged and ready for use. A change in DC current will cause the converter to exit Float Mode and return to the default, or normal, Absorption Mode.

Note: The converter, while in Float Mode, will continue to supply a trickle charge to the battery. If the RV is in storage for thirty (30) days or more, be sure to check the battery and its fluid levels.



⚠ CAUTION

INSTALLATION AND SERVICING

This product should be installed and serviced by a certified or licensed electrician familiar with applicable safety codes and installation requirements. Failure to observe this precaution could result in electrical shock or bodily injury. Consult your servicing dealer before attempting any work on this product.

Converter Output Voltage

Before checking the WF-9800 Series Converter-Charger output voltage, disconnect the battery cables at the battery. Make sure the converter is plugged into an AC source (105-130 Volts). Check the converter output voltage at the battery with a voltmeter. Place the meter probes on the disconnected battery cables; place the Positive (red) meter probe on the + Positive red battery wire and place the Negative (black) meter probe on the -Negative black wire on the battery cable (Figure 3). Be sure you have good connections at the cables. If the voltage reads 13.6 - 14.4 VDC (+/- 0.2) with no load, the converter is functioning properly.

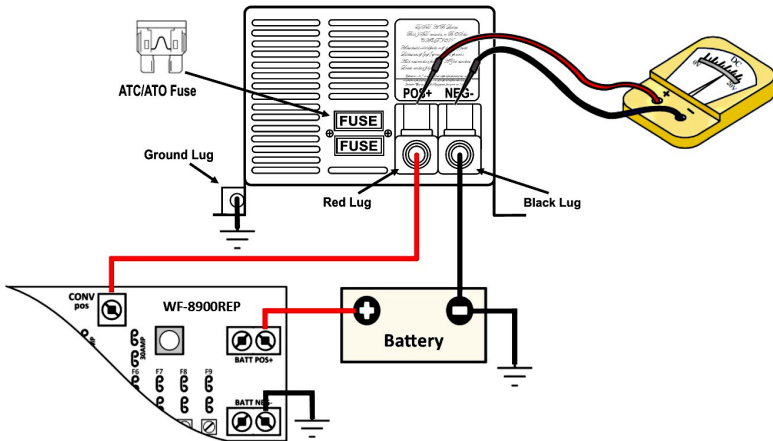

Figure 4

If the converter output voltage at the battery reads 0.0 VDC, or if the battery is not charging, check for an open inline fuse in the battery wire circuit. One may have been installed by the RV manufacturer. Also check for loose wiring connections.

Reverse Polarity Fuses

If there is no DC output coming from the WF-9800 Series Converter-Charger output lugs, first check the reverse polarity fuses on the rear panel. Then, visually inspect the fuses for any breaks in the fuse element. If no breaks are found, use a continuity tester to check for continuity. If the reverse polarity fuses are blown, it means the RV battery was accidentally connected in reverse, either at the battery or at the converter. Investigate the connections and reconnect the cables properly. Replace the fuse with the same type and amperage rating as the original.

IMPORTANT: These fuses protect the converter from damage if the RV battery is accidentally connected in reverse. A reversed battery connection, even if for only a second, will cause these fuses to blow.

If the above checks have been made but the converter output still reads 0.0 VDC, the converter is not functioning properly.

Troubleshooting Guide for WF- 9800 Series Deck Mount Converters

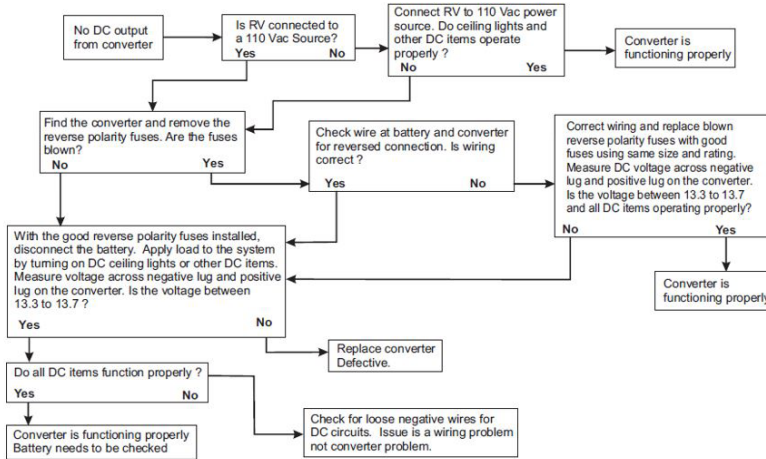

Figure 5

GENERAL COMPLIANCE INFORMATION

Agency Listings

UL

The WF-9800 Series Converter-Chargers are UL-Listed, and cUL-Listed (Canadian).

FCC Compliance Class B

NOTE: This equipment has been tested and found to comply with the limits for a Class B digital device, pursuant to Part 15 of the FCC Rules. These limits are designed to provide reasonable protection against harmful interference when the equipment is operated in a commercial environment. This equipment generates, uses, and can radiate radio frequency energy, and if not installed and used in accordance with the instruction manual, may cause harmful interference to radio communications. Operation of this equipment in a residential area is likely to cause harmful interference in which case the user will be required to correct the interference at his own expense.



WF-9800 Converter Specification			
Model No.	WF-9835	WF-9845	WF-9855
Converter Input Power:			
Voltage	105-130VAC		
Frequency	60Hz		
Max.Input Current @105VAC	7A	9A	11A
Max Power	600 watt	770 watt	940 watt
Converter Output Power:			
Continuous Power:	475 watt	610 watt	750 watt
Rated DC Output Voltage	13.6V		
Rated DC Current	35A	45A	55A
Charging Control	Automatically controlled by microprocessor		
Charging Modes	3-stage Intelligent charge		
Intelligent Charge Modes	Absorption, Bulk and Storage		
Battery Adaptability	LA/AGM		
Absorption Charge Voltage	13.6V		
Bulk Charge Voltage: (4 Hrs)	14.4V		
Storage Charge Voltage	13.2V		
Regulation	± 1% accuracy against input or load changes		
Cooling Fan	Two speed according to the DC load Amperage		
VA Efficiency	> 80% (under 70% of load condition)		
Protection:			
Overload	Current-limiting & shut down; auto recovery upon return to normal load		
Short-Circuit	Shut down & auto recovery upon return to normal		
Over-Temperature	Shut down & auto recovery upon return to normal		
Battery Reverse Polarity	Protected by Fuse; same rated fuse replacement required		
DC Distribution Board:			
DC Battery Lugs: NEG-, POS+	Lugs accept 2 to 14 AWG wire; Lug screws are 5/16" Allen Head		
Mechanical:			
Dimensions	4 5/8"W x 4"H x 7 1/2"D 117.5 mm W x 101.6 mm H x 190.5 mm D	4 3/4"W x 4"H x 8 3/4"D 120.7 mm W x 101.6 mm H x 222.3 mm D	
Weight	4 lbs. / 1.8 kg	5.25 lbs. / 2.4 kg	5.5 lbs. / 2.5 kg
Environmental Condition:	20 ~ 90% Non-condensing		
Agency:	UL458 certified; FCC Class B compliant		

Figure 6



CONSUMER LIMITED WARRANTY for WFCO Electronic Products

WFCO extends, to the original owner, a Two Year Limited Product Warranty. This warranty is in effect from the date of original purchase for a period of two (2) years. This limited warranty is extended specifically for and is limited to Recreational Vehicle application and is only valid within the continental United States, Alaska, Hawaii and the Provinces of Canada. WFCO warrants, to the owner, that its products are free from defects in material and workmanship under normal use and service based on its intended use and function. This warranty is limited to the repair or replacement, at WFCO's discretion, of any defective parts or defective assembly. Any implied warranties of merchantability or fitness for intended use are limited in duration unless applicable State Law provides otherwise. You may have other rights as specified by each individual state.

EXCLUSIONS and LIMITATIONS

The OEM warranty specifically does not apply to the following:

- Any WFCO product that has been repaired or altered by an unauthorized person;
- Any damage caused by misuse, faulty installation, testing, negligence, accident or any WFCO product installed in a commercial vehicle;
- Any WFCO product, whose serial number has been defaced, altered or removed;
- Any WFCO product, whose installation has not been in accordance to the WFCO written instructions;
- Any consequential damages arising from the loss of use of the product including but not limited to: inconvenience, loss of service, loss of revenue, loss or damage to personal property, cost of all services performed in removing or replacing the WFCO product. Specifications are subject to change without notice or obligation.
- Any WFCO Electronics products sold through unauthorized Internet sources (Example: eBay) will be excluded from all warranty coverage offered by Arterra Distribution / WFCO.

CONSUMER WARRANTY CLAIM PROCEDURE

Upon determination and validation by an authorized OEM dealer that a WFCO product has a defect, a Return Goods Authorization (RGA) number will be required before the product can be returned. The RGA number can be requested by completing the Warranty Information Fax Sheet and appropriate Troubleshooting Form found at www.wfcoelectronics.com. Once these forms have been completed, email the forms along with Proof of Purchase to warranty@wfcoelectronics.com or fax the three documents to the Warranty Department at (574) 294-8698. After receipt of the forms, an RGA number will be issued. This number shall appear on all correspondence with warranty service. Upon validation of the warranty, WFCO shall replace the product with a like product. The RGA number shall be placed on the outside of the carton used to return the product for ease of identification. Do not mark directly on the product. The product must be packaged properly to avoid further product damage which could cause a non-warrantable condition.

WARRANTY ASSISTANCE

The consumer may contact the selling Dealer or OEM for warranty assistance. The consumer may also contact Arterra Distribution, exclusive distributor to WFCO Products at: (574) 294-8997 or Fax (574) 294-8698.



WF-8900-REP DIMENSIONAL DRAWING

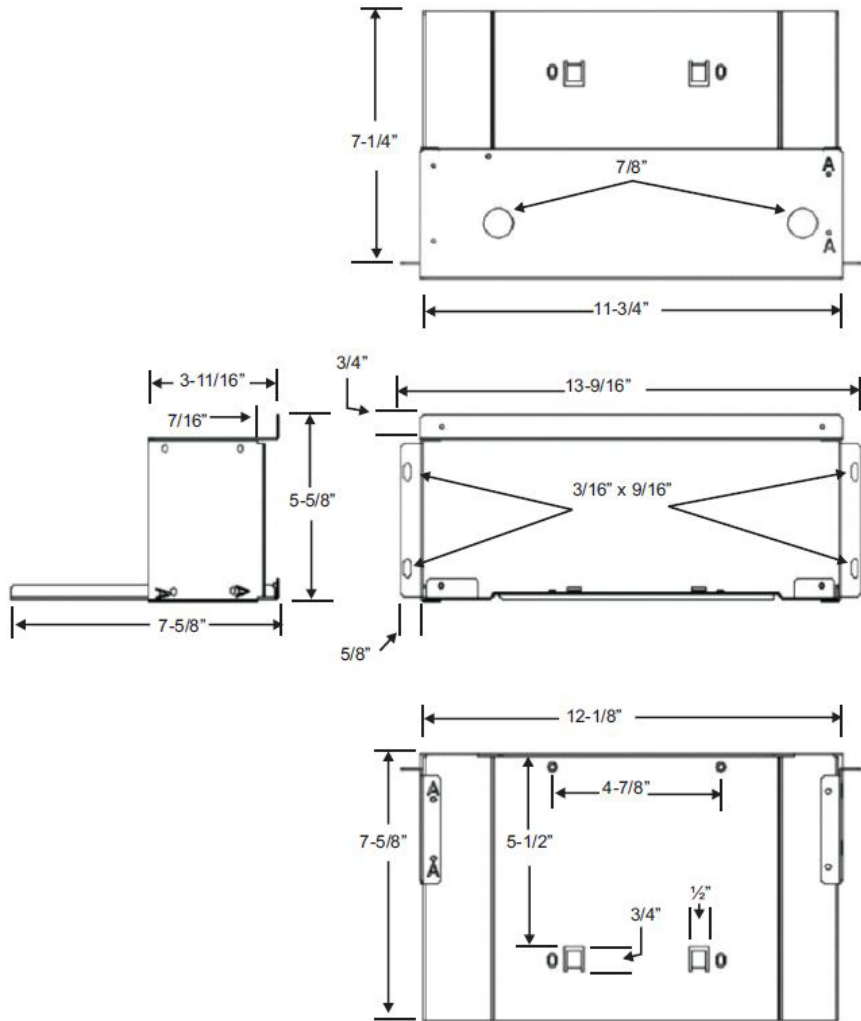

Figure 7





THE HEARTBEAT OF TODAY'S RVs

WFCOELECTRONICS.COM