

INSTRUCTIONS - PLEASE READ CAREFULLY FOR IMPORTANT INFORMATION



INSTRUCTIONS FOR

ULTRAGUARD & PREMIUM ULTRASHIELD RV COVERS

BEFORE USING COVER Read Carefully

Your Camco Gold Coast RV Cover is made of the highest quality materials available. Its intended purpose is to give your RV added protection from dirt, dust and the sun's harmful UV rays that cause fading. There are specific conditions not covered by your warranty. They include modifications or alterations, rips, tears, puncture holes, damage caused by animals, fire, flood, ice, wind and vandalism. Covers damaged by any of the above stated items will not be accepted back for credit or warranty. **No Exceptions.**

If there is a problem with your new cover please do not take it back to the place of purchase. Please call 1-800-334-2004 for warranty assistance.

LIMITED WARRANTY POLICY

If there is a problem with your new cover please do not take it back to the place of purchase. Please call 1-800-334-2004 for warranty assistance.

A. One Time Replacement

Any Camco Gold Coast RV Products RV Cover which becomes unusable due to a defect in material or workmanship within the allotted months of purchase will be replaced only to the original consumer/purchaser by the manufacturer (Camco Gold Coast RV Products). There will be no charge (except for shipping and handling) for this one time replacement.

Note: This is a one-time only replacement policy. If the product has already been replaced once by the manufacturer at no charge, all other warranty replacements will be offered at a prorated cost per the Pro-rata schedule. Please see pro-rata chart for specific information on the replacement schedule for your type of cover.

Detailing/Washing charges, loss of time, inconvenience, or ANY CONSEQUENTIAL DAMAGES do not apply!

B. Pro-Rata Schedule

	TIME OWNED	CONSUMER REPLACEMENT COST
ULTRASHIELD COVERS	0-12 months	No Cost - Complete Replacement
	13-24 months	50% of Manufacturer's Suggested Retail Price
	25-36 months	75% of Manufacturer's Suggested Retail Price
ULTRAGUARD COVERS	0-12 months	No Cost - Complete Replacement
	13-24 months	50% of Manufacturer's Suggested Retail Price

C. Exclusions

Free replacement and Pro-rata periods do not apply in the following cases:

1. If the cover has been damaged due to a failure to follow directions, neglect or abuse.
2. If the cover fails because of fire, explosion, wreckage, collision, high winds, storm conditions, other forms of extreme weather, acts of God and/or vandalism.
3. If tie-downs other than those recommended by the manufacturer are utilized.
4. If no proof of purchase (or copy thereof) can be produced.
5. If the cover was used in an application for which it was not designed.
6. If the cover was not installed per the manufacturer's instructions.
7. If the cover has been altered in any way by a person or commercial entity other than an approved representative of the manufacturer.

D. Liability

Camco Manufacturing assumes no liability in the use of their covers. Please check your owner's manual for recommendations on use of covers.

This warranty gives you specific legal rights, and you may also have other rights, which vary from state to state. **This is a full statement of warranty terms. No other express warranties are made. There are no implied warranties extending beyond the term of the express written warranty stated within.** Some states may limit or augment your rights and the warranty time limits stated.

How to obtain warranty performance:

1. Call a Camco Gold Coast RV Products Warranty Service Representative for a preliminary determination of product performance failure.
2. If cover is determined to be defective, a return number will be issued. This return number must accompany all correspondence regarding the return of the product.
3. Camco Gold Coast RV Products must receive the following items before a replacement will be issued.
 - a. Proof of purchase.
 - b. Product Identification tag (located inside front of cover).
 - c. A photograph or digital picture of the damaged area that contains the defect.
 - d. Payment for any pro-rata adjustment.
 - e. Payment for shipping and handling fees.

IMPORTANT

Important Information

- Check your coach's owner's manual for warnings or contact the manufacturer to verify that you can walk on the roof of your coach, and where it is and is not safe to do so.
- Check owner's manual for notes on compatibility of covers with your coach (some coach manufacturers recommend not covering their coaches).
- Before installing cover make sure that there are no sharp protrusions on the coach that may damage cover. If there are any, use padding or protection to ensure a long life for your cover.
- Use care when on the roof of your coach. Use extreme caution to avoid slipping and falling around sloping or rounded corners and slick surfaces near roof edge.
- Rubber Roofs- If your coach has a rubber roof extreme caution should be used. Check your owner's manual before installing cover to see if roof is compatible with covers. Extra padding (not included) should be used under the straps at roof-to-side transition to prevent chaffing/damage to the roof seams.
- Do not attempt to install cover in windy conditions. Doing so may risk serious injury to the installer and damage to the cover and coach.
- Make sure that coach is dry before installing cover. A slippery, wet roof is a dangerous place to be, and any moisture will attract dirt that may remain underneath the cover after it is installed.
- Install cover on a clean coach for optimum protection. Remember that the cover only protects your coach from dirt on the outside.
- Do not walk on cover after installation on coach. Vents, skylights, antennas and other roof-mounted items may not be apparent, and a misplaced step could cause injury or property damage.
- Do not overtighten tie-downs. The bendable hooks are made of aluminum, and the attached elastic tensioners must not be overstressed when installed or these hooks may be forced open under windy conditions. The tensioners should be installed so that they maintain a "pull" on the tie-down, but still have some stretch left over to absorb any additional stress.
- Periodically check condition of your cover. Examine cover for points of possible wear, loose tie-downs and general fit (especially during or after periods of bad weather).
- Severe storms may damage your cover. Please use common sense in the use of your cover. High winds can exceed the protection capabilities of temporary structures, much less RV covers- consider removing your RV cover when warned of the approach of storm force winds or bad weather.
- **Heat and exhaust concerns:** Move cover away from exhaust pipes, heater vents, etc. before starting vehicle's engine, generator or other heat-emitting accessories. Ensure there is adequate ventilation so that fumes do not gather under the cover.
- Do **Not** operate vehicle or tow trailer while cover is on.

To clean your Camco Gold Coast RV Cover, simply rinse with water. Use a mild soap only when necessary. Strong soaps, detergents or chemical cleaners may diminish water repellency.
Do not over wash! DO NOT SCRUB! Rinse well and hang dry. Do not store wet.
KEEP AWAY FROM OPEN FLAMES.

#607

Manufacturer/Seller will not be responsible for accelerated wear and damage to cover or vehicle resulting from failure to follow manufacturer's instructions.

CAMCO MANUFACTURING, INC.
CONSUMER/WARRANTY INFORMATION

DATE AND PLACE OF PURCHASE: _____

YOUR NAME: _____ PHONE #: _____

ADDRESS: _____

CITY: _____ STATE: _____ ZIP: _____

IMPORTANT!!!

Please Read Instructions Thoroughly Before Using Your Cover

Before using your cover, be sure to check your RV for sharp edges that could tear or puncture holes in the cover. Some problem areas are around awning locks, radio antennas, satellite antennas, rain gutters, ladders, etc.

If you locate sharp edges that cannot be altered, you need to place a protective barrier between any sharp edges and your cover. Examples: towel, rag, foam pad, etc. Stationary antennas need to be removed or positioned down before using your cover. If necessary you may need to pad antenna so it won't tear or puncture through your cover.

CAUTION:

Do not attempt to put cover on during strong winds. Do not install with seams facing out.

Cover is rolled up **back to front**. Both ends of cover, front and back are NOT the same and have been labeled to indicate front and rear.

When unfolding, place cover in the center of roof toward the front of RV. Unroll the front 1/3 of cover and allow front of cover to drape down over front of RV. (See fig 1)

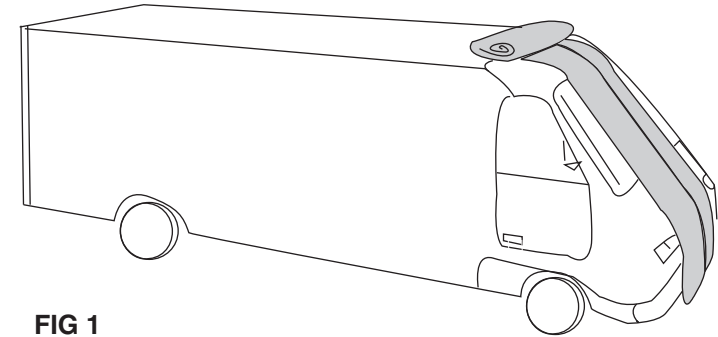

FIG 1

Unfold sides and allow them to fall down over each side of the RV and drape down. Take care to not install inside out. (See fig 2)

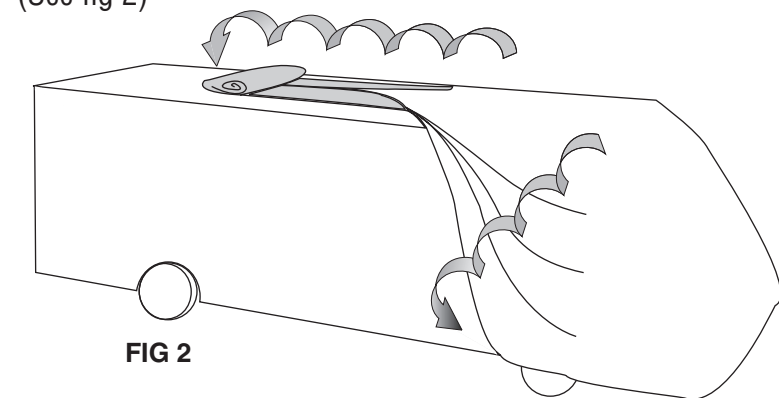

FIG 2

Moving front to back, unroll the rest of cover working your way back to the rear of coach and the ladder. Be mindful of where vents, A/C and antennas are as you unroll and unfold cover to avoid damaging roof vents, etc. (See fig 3)

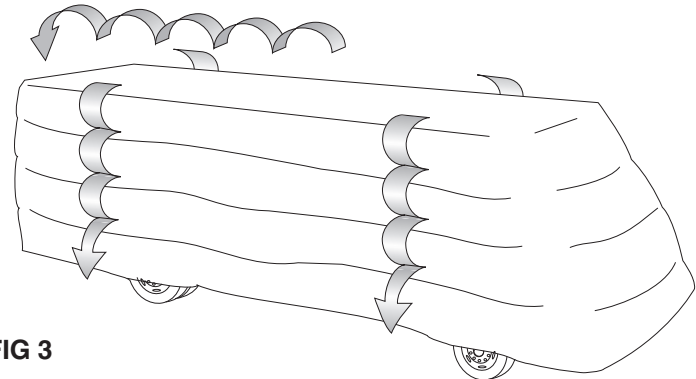

FIG 3

After cover is evenly spread out, walk around coach and adjust as needed. If cover is caught or hung up on something, you may need to lift over obstruction(s). Do not force cover over obstructions and risk tearing.

Both ends have elastic sewn in the bottom edge. It should be pulled down and under front and rear bumpers.

INTEGRATED HOLD-DOWN SYSTEM
(figures 4A, B, C, D, & E)

Camco Gold Coast RV Product's unique Hold Down system makes it easy to secure your RV cover. First bend the bendable strap end to form a hook (See Fig 4A and 4B).

FIG 4A

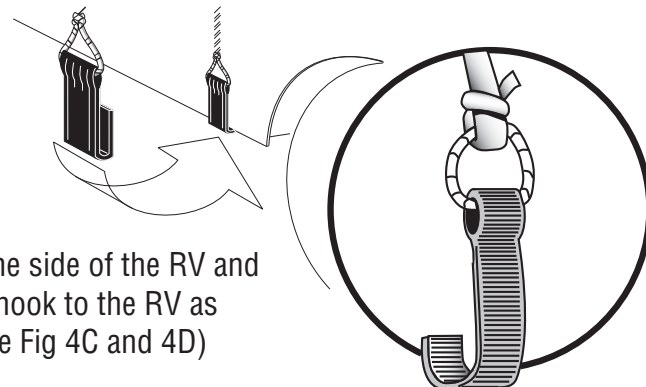

FIG 4B

Begin on one side of the RV and secure the hook to the RV as shown. (See Fig 4C and 4D)

FIG 4D

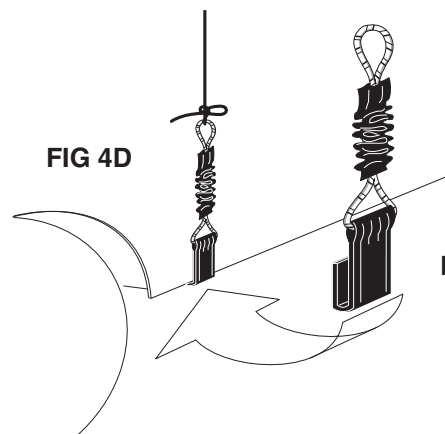

FIG 4C

Pull the tie down taut. Temporarily tie using a slip knot as shown (See Fig 4E). Repeat for all tie-downs. Do not over tighten. The bendable hooks are made of aluminum, and the attached elastic tensioners must not be over stressed when installed or these hooks may be forced open under windy conditions. The tensioners should be installed so that they maintain a "pull" on the tie-down, but still have some stretch left over to absorb any additional stress.

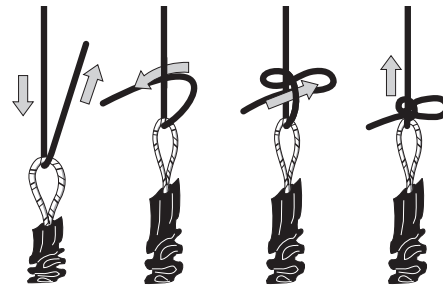

FIG 4E

Once you are satisfied with the fit of the cover (i.e. properly centered on the RV), the tie downs can be permanently tied using two half hitch knots and the excess strap material trimmed.

If your coach has a swept back front design be sure to fold excess material down towards center of coach and secure with Tie-Downs as shown. (fig 5)

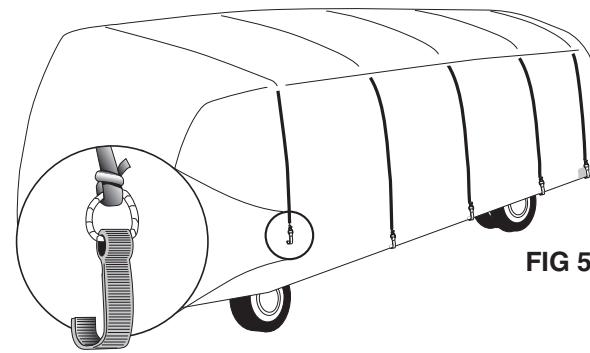

FIG 5

Covers are equipped with reinforcement flaps that have an integrated strap buckle. Cinch up to take up extra material (there are two sets of flaps and buckles for the front and back of the cover). Snap both sets of buckles together and then pull on the straps to tighten.

CAUTION: DO NOT OVERTIGHTEN the bungee tie-downs or the front and back straps. Seams can cause friction damage to the soft rubber roofs of RV if the cover is too tight.

Covers are for storage *only* and not to be used for towing.

Your RV cover has been fabricated using the finest material and workmanship. To prolong its lifetime and performance you will need to consider its #1 enemy: WIND! It is important to periodically check the cover to make sure it is properly secured, especially during and after high winds.

A loose cover flapping in the wind will damage, chafe and eventually wear through the cover in stressed areas. By using the self adjusting Tie-Downs and making sure loose areas of the cover are secure and not allowed to blow out or flap against sharp objects, your cover will perform to its fullest potential.

Likewise, proper storage of cover will add to its life. If cover is badly soiled, hose off and allow to dry completely before re-folding for storage.

All covers include a handy storage bag.

IMPORTANT!

FAILURE TO FOLLOW THESE INSTRUCTIONS MAY VOID YOUR WARRANTY!



Camco Manufacturing, Inc.
121 Landmark Drive • Greensboro, NC 27409
800-334-2004 • 336-668-7661
www.camco.net

CAUTION: DO NOT OPERATE VEHICLE WITH COVER INSTALLED. DO NOT RUN ENGINE, GENERATOR OR OTHER SYSTEMS THAT EXPEL HOT AND/OR TOXIC GASES WITH COVER INSTALLED.

TO VALIDATE YOUR WARRANTY FILL OUT CARD BELOW, APPLY POSTAGE STAMP AND MAIL TO CAMCO MANUFACTURING, INC.



Camco Manufacturing, Inc.
121 Landmark Drive
Greensboro, NC 27409



PLACE
STAMP
HERE