

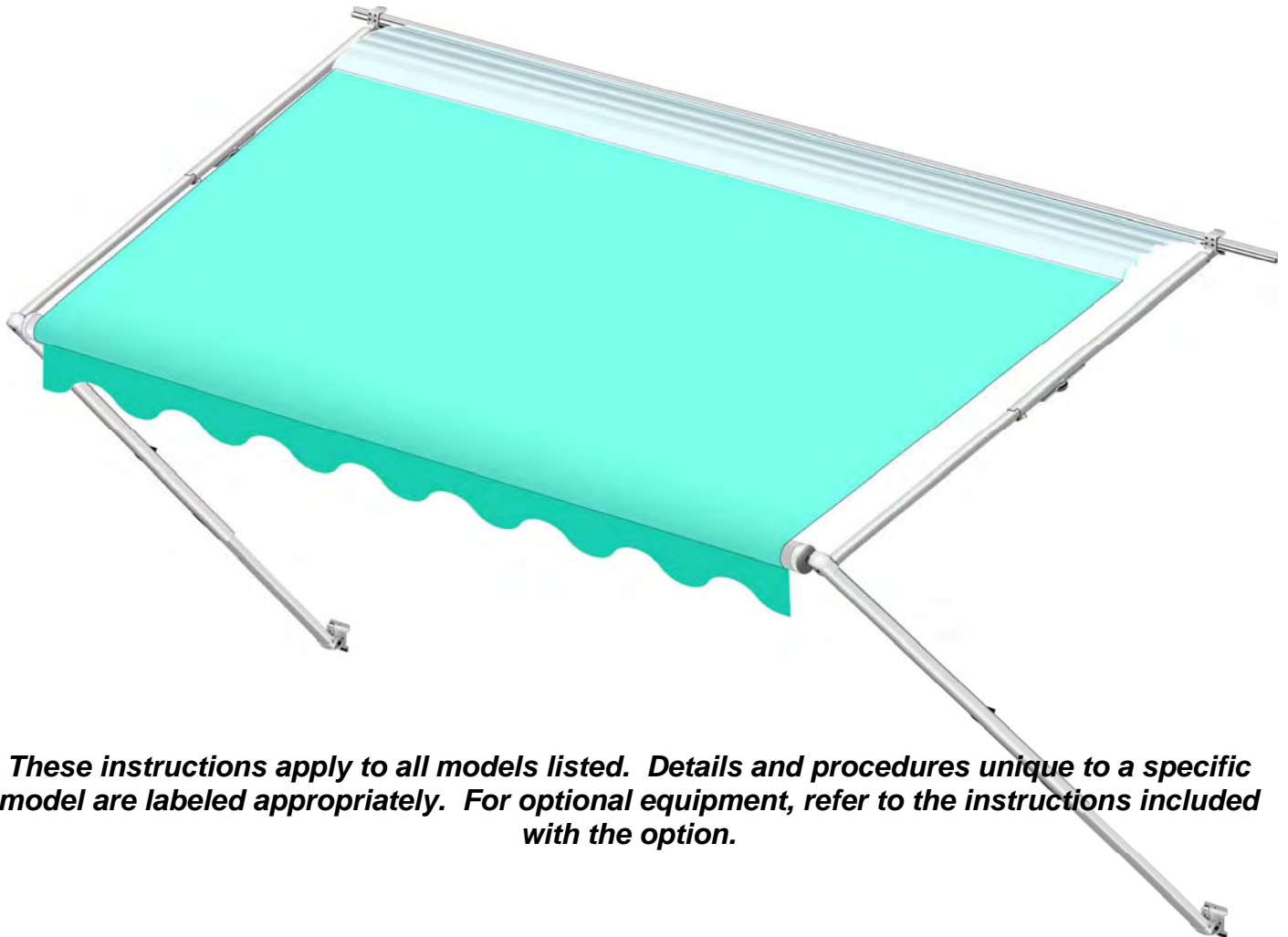

MANUALLY OPERATED PATIO AWNING

SPIRIT FX, FIESTA AND SIMPLICITY AWNINGS

RV



These instructions apply to all models listed. Details and procedures unique to a specific model are labeled appropriately. For optional equipment, refer to the instructions included with the option.

TABLE OF CONTENTS

Component Checklist..... 1

Installation 2

 General Layout2

 Installing an awning rail (if required)2

 Assembling the Awning3

 Mounting the Bottom Mounting Brackets.....3

 Mounting the Awning4

 Installing the Stop Bolt.....5

 Securing the Fabric5

 Installing the Rubber Bumpers5

 Thin-Lite Power (Spirit FX only).....6

PROPRIETARY STATEMENT

The manual Patio Awning is a product of Carefree of Colorado, located in Broomfield, Colorado, USA. The information contained in or disclosed in this document is considered proprietary to Carefree of Colorado. Every effort has been made to ensure that the information presented in the document is accurate and complete. However, Carefree of Colorado assumes no liability for errors or for any damages that result from the use of this document.

The information contained in this manual pertains to the current configuration of the models listed on the title page. Earlier model configurations may differ from the information given. Carefree of Colorado reserves the right to cancel, change, alter or add any parts and assemblies, described in this manual, without prior notice.

Carefree of Colorado agrees to allow the reproduction of this document for use with Carefree of Colorado products only. Any other reproduction or translation of this document in whole or part is strictly prohibited without prior written approval from Carefree of Colorado.

SAFETY INFORMATION

WARNING

A WARNING INDICATES A POTENTIALLY HAZARDOUS SITUATION WHICH, IF NOT AVOIDED, COULD RESULT IN DEATH OR SERIOUS INJURY AND/OR MAJOR PROPERTY DAMAGE.

CAUTION

A CAUTION INDICATES A POTENTIALLY HAZARDOUS SITUATION THAT MAY CAUSE MINOR TO MODERATE PERSONAL INJURY AND/OR PROPERTY DAMAGE. IT MAY ALSO BE USED TO ALERT AGAINST UNSAFE PRACTICES.

NOTE: A note indicates further information about a product, part, or step.

Tip: A tip provides helpful suggestions.

Safety Notes:

- Always disconnect battery or power source before working on or around the electrical system.
- Always wear appropriate safety equipment (i.e. goggles).
- Always use appropriate lifting devices and/or helpers when lifting or holding heavy objects.
- When using fasteners, use care to not over tighten. Soft materials such as fiberglass and aluminum can be "stripped out" and lose the ability to grip.

REFERENCE PUBLICATIONS LOCATED @ www.carefreeofcolorado.com:

052876-005 Patio Awning Installation Manual

052876-201 Patio Awning Owner's Manual

052876-301 Patio Awning Service Manual

Awning Accessory Manuals:

052787-003 Thin-Lite Installation & Operation Manual

052796-001 Power Pack Installation

052806-003 Automatic Awning Support

052807-004 Rafter VI Installation & Operation Manual

052959-001 Rafter VII Installation & Operation Manual

COMPONENT CHECKLIST

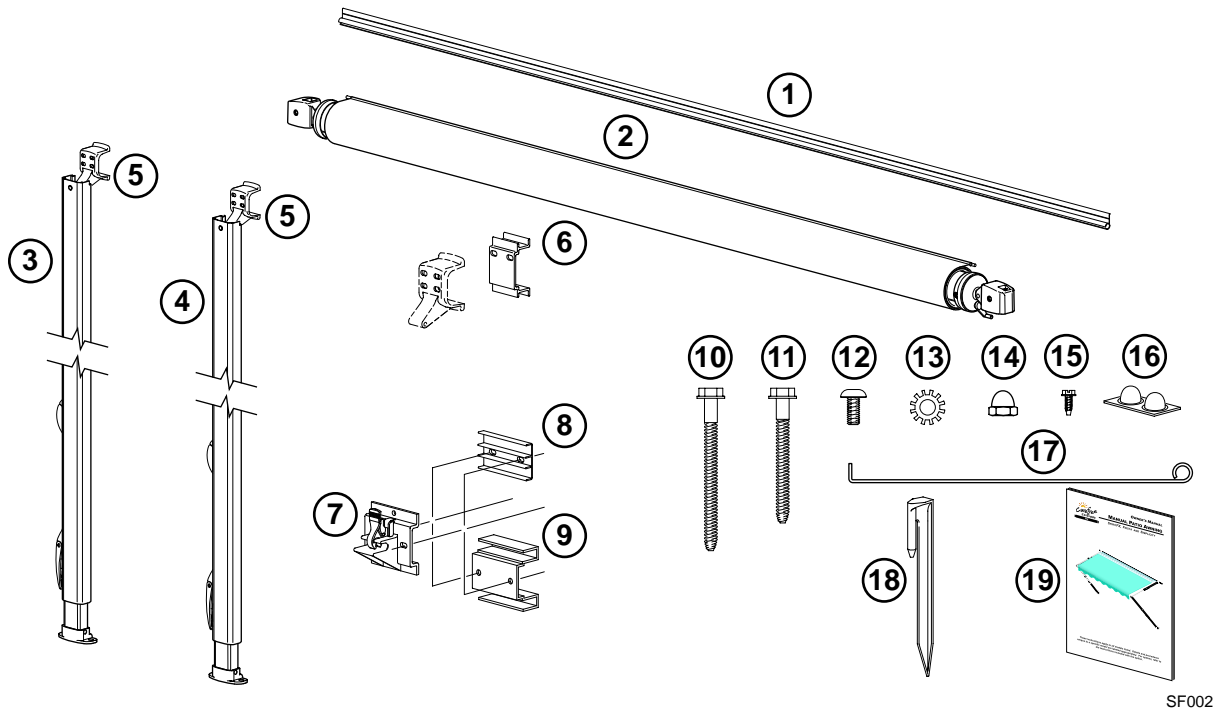

SF002

Figure 1. Component Checklist.

<input checked="" type="checkbox"/>	ITEM	DESCRIPTION		QTY	NOTE
BASIC ASSEMBLY					
<input type="checkbox"/>	1	Awning Rail		1	3
<input type="checkbox"/>	2	Roll Bar Assy		1	1
<input type="checkbox"/>	3	Arm Assy, LH		1	1
<input type="checkbox"/>	4	Arm Assy, RH		1	1
<input type="checkbox"/>	5	Upper Mounting Bracket		REF	2
<input type="checkbox"/>	6	Upper Bracket Stand-off, Optional		2	3
<input type="checkbox"/>	7	Lower Mounting Bracket		2	
<input type="checkbox"/>	8	Lower Bracket Shim, Optional		2	3
<input type="checkbox"/>	9	Lower Bracket Stand-off, Optional		2	3
<input type="checkbox"/>	10	Lag Screw	1/4 x 3	4	
<input type="checkbox"/>	11	Lag Screw	1/4 x 2 1/2	4	
<input type="checkbox"/>	12	Screw, Quadrex Head	1/4-20 x 7/16	4	
<input type="checkbox"/>	13	Lock Washer	1/4	2	
<input type="checkbox"/>	14	Nut, Cap	1/4-20	2	
<input type="checkbox"/>	15	Screw, Hex Washer Head	#6 x 3/8	2	
<input type="checkbox"/>	16	Bumpers (set of 2)		1	
<input type="checkbox"/>	17	Pull Wand		1	
<input type="checkbox"/>	18	Carport Ground Stake		4	4
<input type="checkbox"/>	19	Owner's Manual		1	5

- Notes:
1. Awning configuration is specified at time of order, including awning length, fabric, color etc. Check awning assembly against original purchase order.
 2. The upper mounting bracket is pre assembled with the arm assy and is shown for reference only.
 3. Awning rail (item 1), and the upper and lower stand-off brackets and shim (items 6, 8 & 9) must be ordered separately.
 4. Carport Ground Stakes are optional must be ordered separately.
 5. Place Owner's Manual with RV owner information. Installation manual, if included, is for installer reference.

INSTALLATION

GENERAL LAYOUT

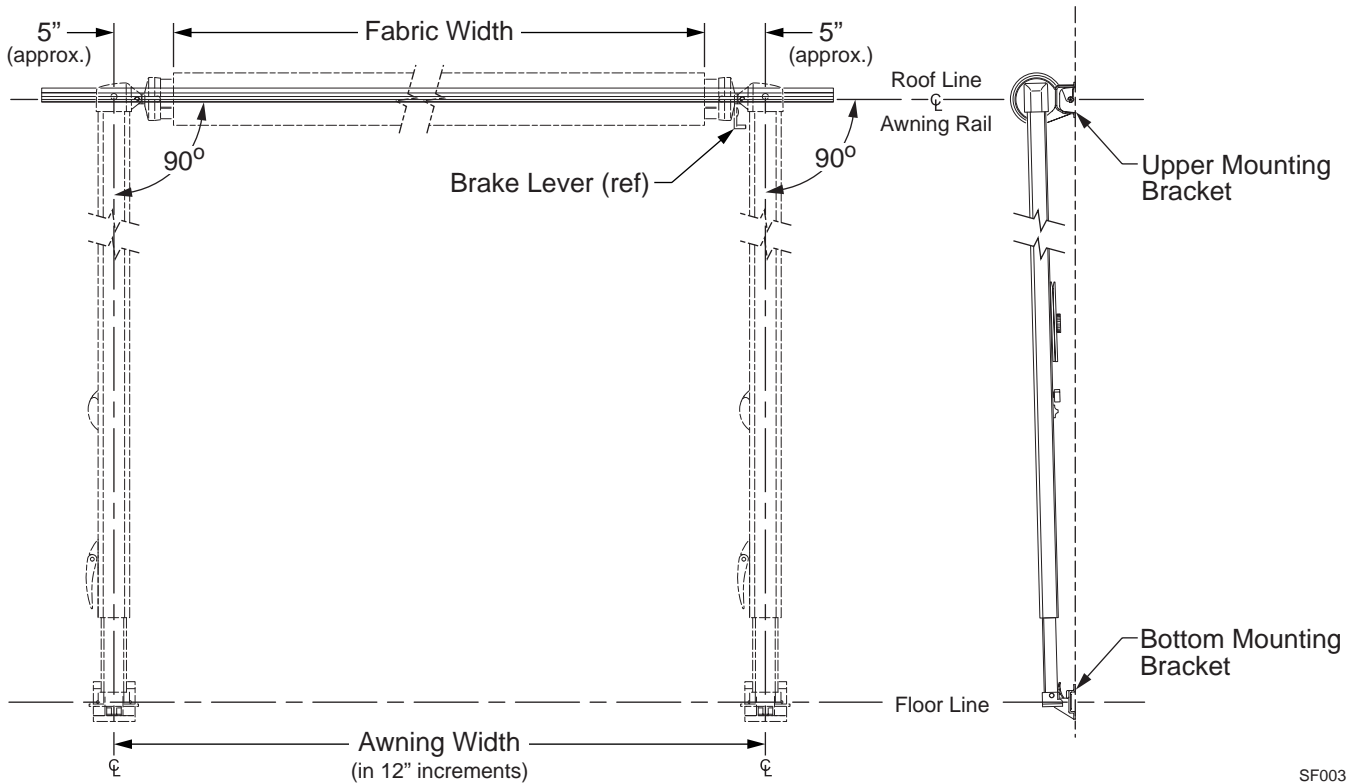

SF003

Figure 2. General Layout.

INSTALLING AN AWNING RAIL (IF REQUIRED)

1. Position the awning rail along the roof line (line where roof and wall meet) or a minimum of 6" above the upper edge of the door or windows the awning is covering. Awning rail must be level and parallel with the floor line of the vehicle.
2. After determining mounting position, mark the position with a chalk line.
3. Seal the back of the rail with silicone sealant or putty tape.
4. Align the awning rail onto the wall and secure with #10 x 3/4" screws. Use all the attachment holes in the rail.
5. Use a screwdriver to spread open the left end of the awning rail on the installation side.

6. File any sharp edges or burrs from the end of the rail. This will help protect the awning fabric from damage during installation.
7. Spray inside the awning rail track with silicone lubricant.

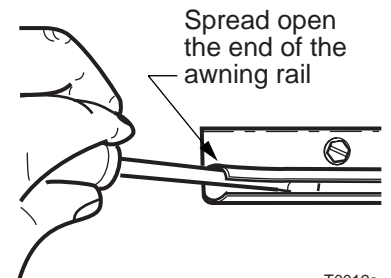

T0012a

Figure 3. Installing the Awning Rail.

ASSEMBLING THE AWNING

⚠ CAUTION

DO NOT REMOVE THE FOLLOWING ITEMS UNTIL INSTRUCTED TO DO SO IN THE INSTRUCTIONS. 1) TAPE AROUND THE CANOPY; 2) THE SAFETY PIN IN THE ROLL BAR (THIS IS HOLDING THE PRE-WOUND SPRING TENSION); OR, THE NYLON STRAP HOLDING THE ROLL BAR BRAKE LEVER. REMOVING THESE ITEMS PREMATURELY MAY CAUSE PERSONAL INJURY, DAMAGE TO THE AWNING AND CAUSE THE AWNING TO NOT OPERATE CORRECTLY.

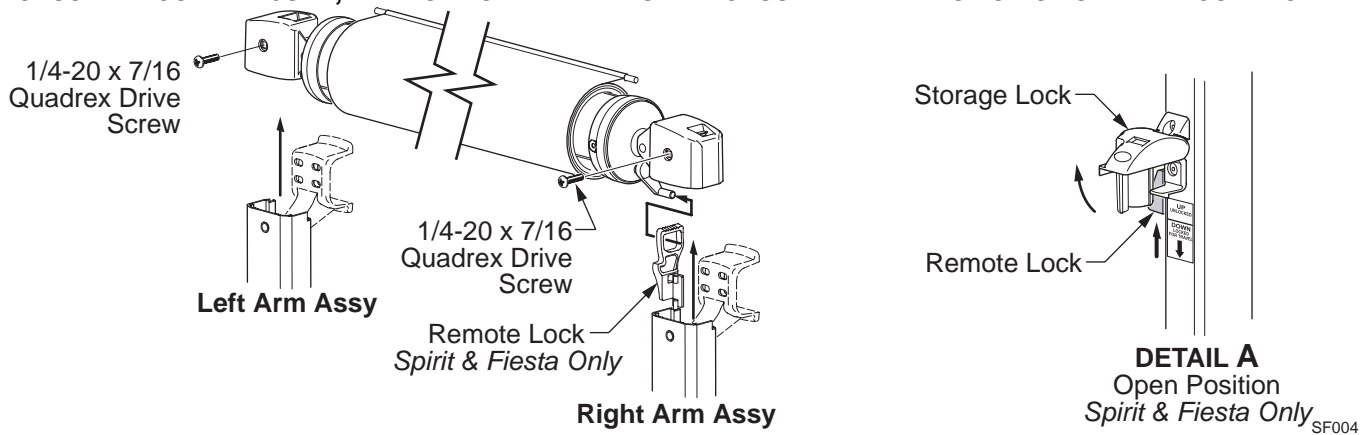

Figure 4. Assembling the Awning.

- On a flat surface, layout the arms and rollbar assembly.
 - Position the rollbar with the fabric oriented as shown over the top with the edge toward the coach. The brake lever must be on the right side.
 - For Spirit and Fiesta – The right arm assembly has the remote lock.
- For All Models: Slide the left arm into the left end plug of the roll bar. Align the holes and secure using one (1) 1/4-20 x 7/16 Quadrex Drive screw.
- For Simplicity: Repeat step 2 for the right arm assembly.
- For Spirit and Fiesta: Hook the remote lock over the brake lever while sliding the arm into the right end plug. Align the holes in the arm and end plug and secure using one (1) 1/4-20 x 7/16 Quadrex Drive screw.

Tip: Release the travel lock and slide the remote lock up until it protrudes over the arm. Hook the remote over the brake lever. Allow the remote lock to slide back into the channel while sliding the arm into the end plug. REMEMBER TO CLOSE THE TRAVEL LOCK WHEN DONE.
- Measure and confirm the width of the awning. The distance is measured from centerline of arm to centerline of arm. (Refer to Figure 2 on page 2.)

MOUNTING THE BOTTOM MOUNTING BRACKETS

- On the awning rail, mark the position of the centerlines of the arms. Ensure that the arms will not interfere with any lights, vents or other obtrusions.
- Using a non-permanent method of marking such as a chalk line, mark a perpendicular line from the awning rail down to the floor line. This is the centerline of the arms.
- Position and attach the bottom mounting brackets. These should be centered on the lines made in the previous step and MUST be attached to the structure at the floor line of the vehicle. Attach using 1/4 x 2/12 lag screws.

NOTE: The bracket is made to straddle the trim found at the floor line. A flat shim is available for mounting to flat areas without trim. If it is necessary to space the bracket out from the wall, a spacer bracket is available. Shim and spacer must be ordered separately.

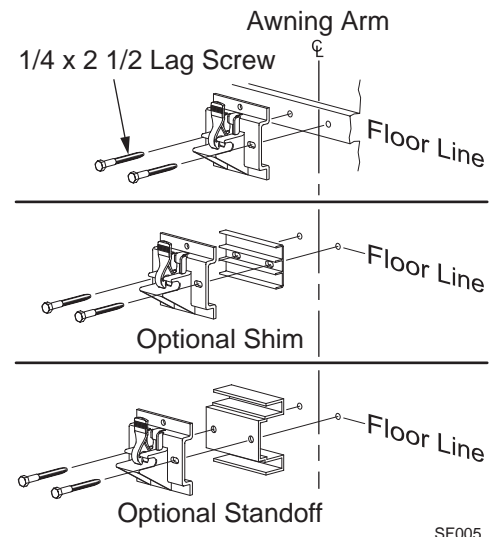

Figure 5. Mounting the Bottom Brackets.

MOUNTING THE AWNING

1. Measure the distance from the awning rail to the bottom mounting brackets.
2. Adjust the arm length so the distance from the center of the roller to the foot is approximately equal to the measurement in step 1.
 - To adjust arm length, open the arm handle and slide the lower channel up or down as required. Close the handle and slide the lower channel until the locking pin clicks into the nearest positioning hole.
3. Remove the tape from the canopy. Unwrap a small portion of canopy but not more than one wrap.

The next step will require two additional people. One to feed the canopy into the awning rail; two to "walk" the arms while the canopy is slid into position.

4. Slide the polycord edge of the canopy (or alumiguard) into the awning rail. Continue to "walk" the arms and canopy down the rail until the arms are in line with the centerline marks made previously.
5. Lift the arm up and secure the foot into the bottom bracket. Repeat for both arms.
6. Firmly grasp the roll bar and remove the safety cotter pin from the left end of the roll bar. Allow the fabric to SLOWLY roll up.

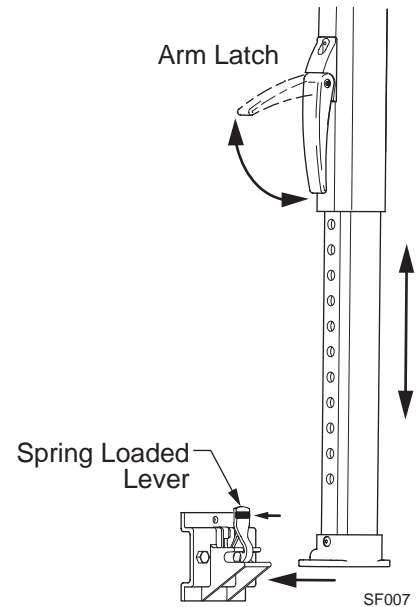

Figure 6. Adjusting Lower Arm.

⚠ CAUTION

USE CARE WHEN REMOVING THE COTTER PIN. THE PIN IS HOLDING THE PRE-WOUND TENSION OF THE SPRING. FAILURE TO SECURELY HOLD THE ROLLBAR MAY ALLOW THE ROLLBAR TO RAPIDLY ROLL UP AND CAUSE PERSONAL INJURY OR DAMAGE.

7. Remove the nylon strap holding the brake lever.
8. Carefully open the awning 12 – 18 inches to provide access to the upper mounting bracket.
 - *For Simplicity:* Unsnap the arm retaining strap and move the brake lever into the OPEN position.
 - *For Spirit and Fiesta:* Open the arm storage lock and move the remote lock up.
 - USE THE PULL STRAP and pull the awning out.
9. Loosen the black locking knob on the upper brace.
10. Slide the upper portion of the brace up so that the upper mounting bracket straddles the awning rail.
11. Center the bracket on the arm centerline drawn earlier.
12. Attach the upper bracket using two (2) 1/4 x 3 lag screws. The screws must go into the vehicle structure. It is acceptable that the screws go through the flat portion of the awning rail.
13. Repeat steps 9 through 12 for the other arm.

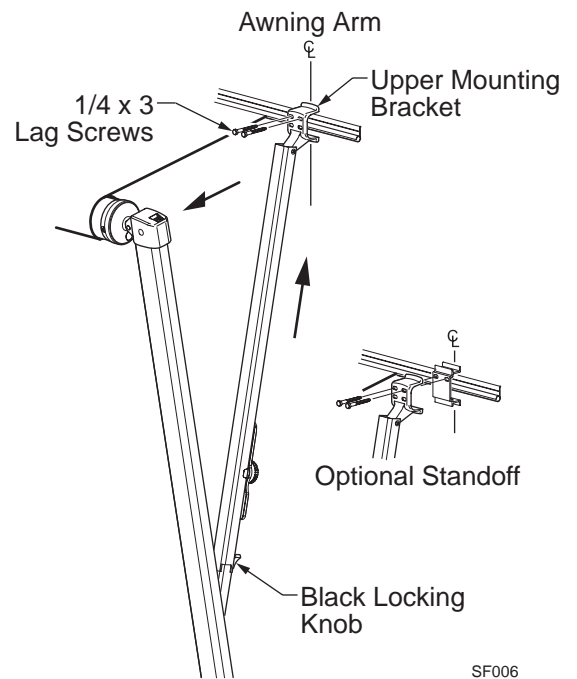

Figure 7. Attaching Upper Mounting Bracket.

NOTE: The bracket is made to straddle the awning rail. If it is necessary to space the bracket out from the wall, a spacer bracket is available and must be ordered separately.

Installing the Stop Bolt

1. Retract the awning.
2. Observe if the centerline of the roll bar is level with or slightly higher than the centerline of the awning rail. (Refer to page 2.) The bottom of the roll bar must not be higher than the awning rail.
3. Adjust the arm length as required. Open the arm handle and slide the lower channel up or down as required. Close the handle and slide the lower channel until the locking pin clicks into the nearest positioning hole.
4. Mark the position stop hole that is directly below the upper channel.

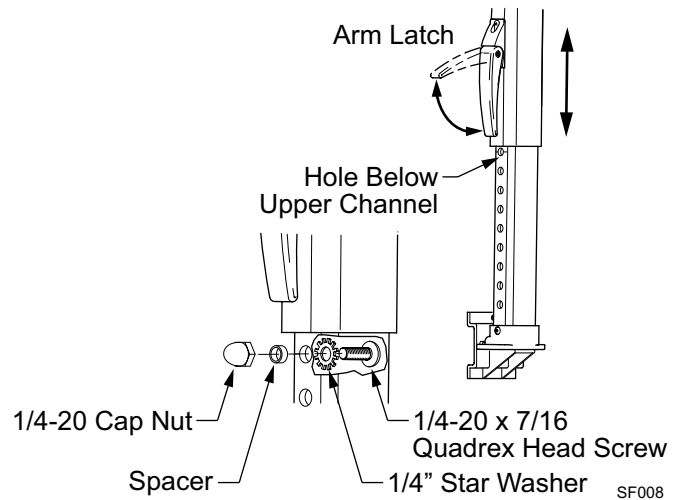

Figure 8. Stop Bolt.

5. From the inside of the channel, insert a 1/4-20 x 7/16 quadrex head screw with a star washer through the hole. Slide the centering spacer over the screw and inside the mounting hole. Secure with a 1/4-20 cap nut.

Tip: It may be necessary to lift the upper channel to tighten the cap nut.

6. Repeat for other arm.

Securing the Fabric

1. Roll the awning in and out several times to make sure that the fabric is square on the rollbar.
2. (refer to Figure 9) Secure the canopy fabric or Alumaguard using one, #6 x 3/8" hex head screw at both sides of the awning.

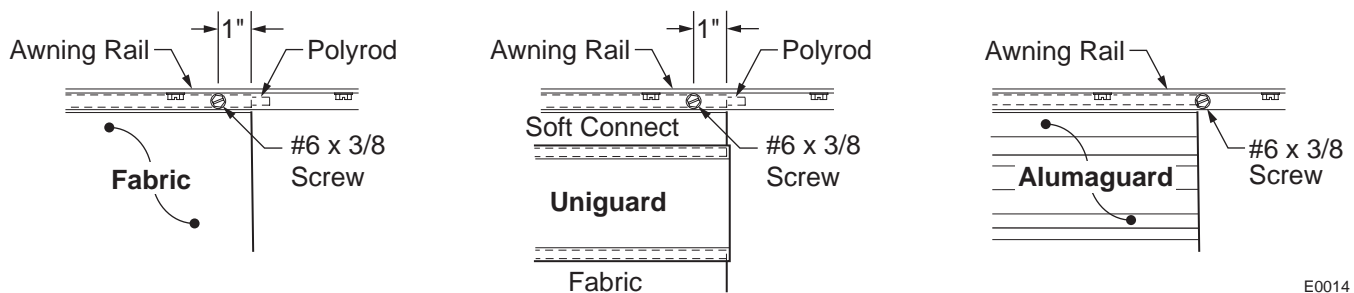

Figure 9. Securing the Fabric.

- 2.1 For vinyl awnings, place screw through awning rail, polyrod and canopy approximately 1" in from the end of the fabric.
- 2.2 For Uniguard awnings, place screw through awning rail, polyrod and the soft connect material approximately 1" in from the end of the fabric.
- 2.3 For Alumaguard awnings, place screw on the outer edge of the Alumaguard.

Installing the Rubber Bumpers

Because of vibration and movement, it may be necessary to "tighten" the awning arms when stored in the travel position. Two rubber bumpers are provided for this purpose.

1. Open the awning to expose the top of the upper brace.
2. Peel and stick a rubber bumper on the upper brace, opposite the locking knob as shown.
3. Repeat for second arm.

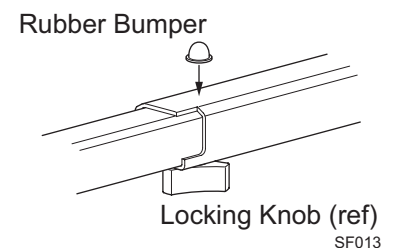

Figure 10. Installing the Rubber Bumpers.

THIN-LITE POWER (SPIRIT FX ONLY)

The Thin-Lite is powered by the vehicle's 12VDC system. An exterior receptacle is used for the light cord plug.

1. Determine the location of the receptacle.
 - Locate the receptacle so that there is easy access to a 12VDC power source such as interior overhead cabinet lights, a 12VDC switch near the door etc.
 - Determine the position of the receptacle so that it can be comfortably reached for easy operation.
 - Position the bracket and receptacle so that when the cord is plugged in it does not create an obstacle (i.e. headroom for walking under).
2. At the predetermined location, drill an 11/16 inch hole into the mounting surface.
3. Attach the receptacle to the bracket as shown.
4. Route the wires from the receptacle through the hole drilled in step 2. Position the bracket and receptacle over the hole and attach using two (2) #6 x 1/2 screws.
5. Two wire clips are furnished, it is not necessary to trim or strip the wires. Place the bottom of the clip over the existing wire in the coach; insert the wire from the receptacle into the top hole of the clip then, with a pair of pliers, squeeze the metal plate into the plastic housing then close the plastic cover. Receptacle wires are marked (+) for 12VDC and (-) for ground.

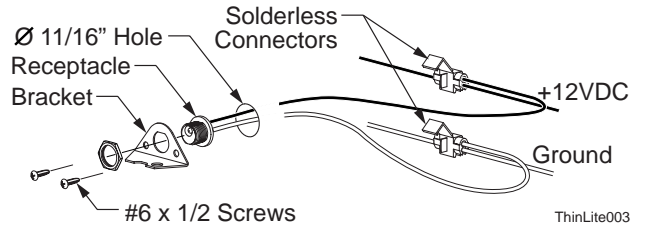

Figure 11. Mounting the Power Receptacle.