

Installation Instructions

P/N 5562009 GM Front Suspension Kit

Before you begin assembling the suspension kit, verify that you have received all the parts listed in the bill of materials.
 Please refer to buyersproducts.com for applications.

Fits the following vehicles:

- Pickups
- GM 1500 Sierra, Silverado, Denali...(excl. XFE Series)
 - 2007-12 2WD Front
 - 2007-12 4WD Front
 - GM 1500 Sierra, Silverado...(XFE Series)
 - 2009-12 2WD Front

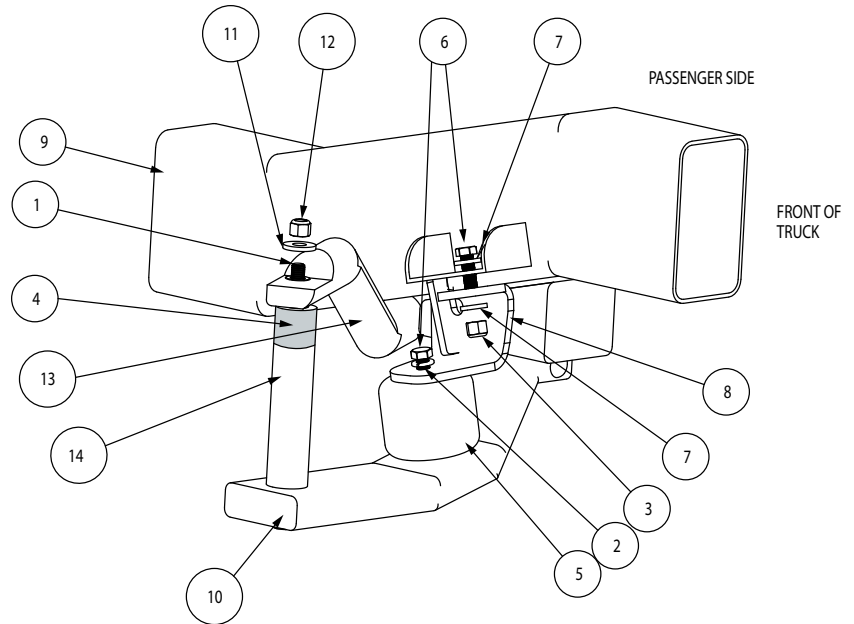

1. Raise vehicle. Axle should not hang freely.
2. If OEM stabilizer bar is equipped on the vehicle insert bushing #4 between the stabilizer bar and stabilizer end link as shown in the diagram. Replace OEM bolt with bolt #1. OEM nut can be used. Apply Loctite to threads.
NOTE: Use penetrating fluid when removing OEM fasteners.
3. Assemble and mount suspension kit as shown in the diagram. Use supplied fasteners.
4. Verify that all connections are tight.
5. Lower vehicle.
6. Steering wheel should be turned in both directions full lock. This will confirm that there is no contact with suspension kit.

Bill of Materials

ITEM	PART NO.	QTY.	DESCRIPTION
1	3015796	2	Bolt, 10mm-1.5 x 220mm, GRD 8.8, ZN
2	3015798	2	Washer, Lock, RHS 3/8", ZN YEL
3	3015799	2	Nut, 3/8"-24 with Nylon Insert, ZN YEL
4	3015800	2	Bushing, 0.75 OD 0.421 ID, Black
5	3011115	2	Suspension Spring
6	3015795	4	Bolt, 3/8"-24 x 1.25", GRD 8, ZN YEL
7	3015797	4	Washer, Flat, 3/8" x 13/16", ZN YEL
-	3015217	1	Mounting Bracket, DS
8	3015218	1	Mounting Bracket, PS
9	-	-	Truck - Frame
10	-	-	Truck - Suspension Bar
11	-	-	Existing Washer
12	-	-	Existing Nut
13	-	-	Truck - Stabilizer Bar
14	-	-	Stabilizer Bar End Link

Warranty

Buyers Products Co. warrants all truck/trailer hardware manufactured or distributed by it, to be free from defects in material and workmanship for a period of one year from date of shipment. Parts must be properly installed and used under normal conditions. Any product which has been altered, including modification, misuse, accident or lack of maintenance will not be considered under warranty. Normal wear is excluded. The sole responsibility of Buyers Products Co. under this warranty is limited to repairing or replacing any part or parts which are returned, prepaid, and are found to be defective by Buyers Products Co. Authorization from Buyers Products Co. must be obtained before returning any part. No charges for transportation or labor performed on Buyers' products will be allowed under this warranty.