



PIONEER PATIO AWNING

Before starting, read and understand all instructions in this manual. Layout the tools listed on page 2.



TABLE OF CONTENTS

Introduction	2
Tools:.....	2
Component Checklist	3
Assembling the Awning.....	4
Attach the End Plug Assemblies to the Roller Tube	4
Attach the Arms to the End Plugs.....	5
Installing the Awning	5
Mounting the Lower Brackets	5
Mounting the Awning	6
Installing the Stop Bolt.....	7
Installing the Rubber Bumpers	7
Securing the Fabric	8
Installing the Tractioners	8
Manual Crank Handle Storage Clips	9
LED Switch Installation (Factory Option).....	10
Wire Routing, Standard	10
Switch Installation.....	10

INTRODUCTION

From its beginning in the early 70's, Carefree of Colorado has emerged as the premier manufacturer of quality awnings and accessories for Recreational Vehicles (RVs). Our full line of products can provide the accessories that match your life style; no matter what type of RV you own.

Check with your dealer to discover the products that can make your life more Carefree.

The clean molded lines of Carefree's Pioneer Patio Awning are stylized to match Carefree's line of Patio Awnings. Built with Carefree's attention to quality, value and style, this awning is the perfect compliment for any RV.

- Simple manual operation. No springs to deal with.
- No travel locks required. The manual crank holds the awning securely against billowing during travel.
- When the awning is extended, the arms can be left on the RV or rotated down and placed in the carport position (vertical).
- The pitch can be set to provide the best shade and rain run off.
- Installation is simple.
 - The fabric is attached to the RV using a standard awning rail.
 - Each arm is attached at the top and secured in a spring loaded bracket at the bottom.

Safety Notes:

The following should always be observed when assembling the awning:

- Always wear appropriate safety equipment (i.e. safety glasses).
- Always use appropriate lifting devices and/or helpers when lifting or holding heavy objects.
- Do not over tighten fasteners. Soft materials such as fiberglass and aluminum can be "stripped out" and lose the ability to grip.

TOOLS:

Tools are not included in kit. The items listed below are available at local hardware stores. Installer must furnish the following items:

Required

- Tape Measure
- Drill Motor/Driver
- #2 Phillips Driver Bit
- #2 Square Driver Bit
- 1/4" Socket Driver Bit
- 1/4" Socket
- 7/16" Socket
- Ladder
- Pencil or marker
- Small tube of silicone sealant

Suggested

- Second Ladder
- Carpenter's Square
- Alcohol Cleaner
- Cleaning Rag
- Dry silicone lubricant (spray)

COMPONENT CHECKLIST

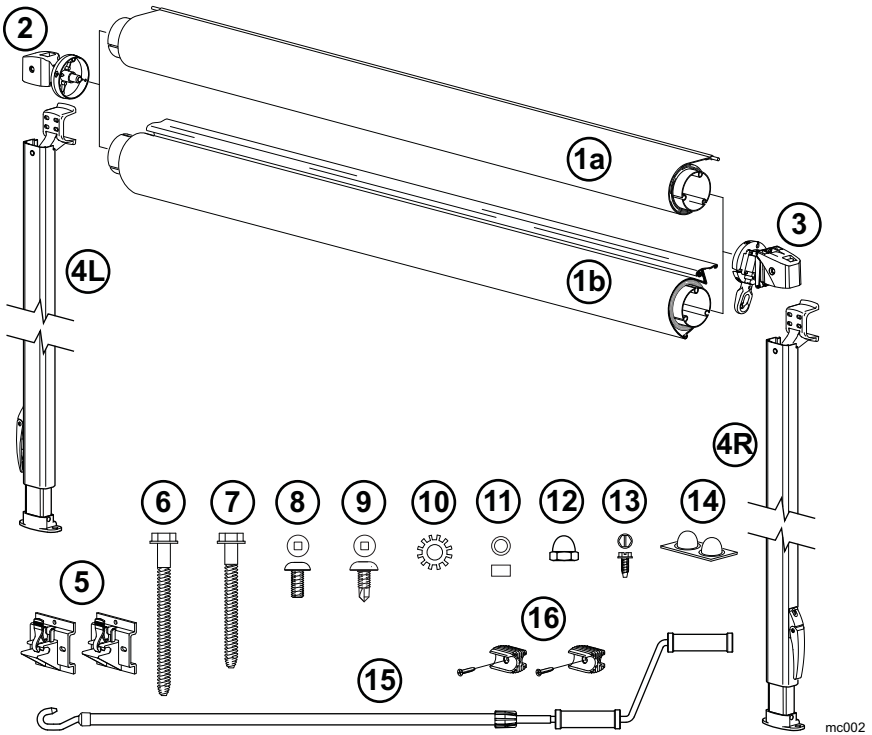

mc002

☑	ITEM	DESCRIPTION	QTY	NOTES
<input type="checkbox"/>	1a	Roller Tube with Fabric	1	
<input type="checkbox"/>	1b	Roller Tube with Fabric and Uniguard	1	1
<input type="checkbox"/>	2	Idler End plug Assembly	LH	1
<input type="checkbox"/>	3	Manual Crank End plug Assembly	RH	1
<input type="checkbox"/>	4	Arm Assembly, LH Latch Lever	1	2
<input type="checkbox"/>	4	Arm Assembly, RH Latch Lever	1	2
<input type="checkbox"/>	5	Bottom Bracket	2	
<input type="checkbox"/>	6	Lag Screw	1/4 x 3	4
<input type="checkbox"/>	7	Lag Screw	1/4 x 2 1/2	4
<input type="checkbox"/>	8	Screw, Square Drive	1/4-20 x 7/16	4
<input type="checkbox"/>	9	Screw, Truss Head Square Drive	#10 x 5/8	5
<input type="checkbox"/>	10	Lock Washer	1/4	2
<input type="checkbox"/>	11	Spacer		2
<input type="checkbox"/>	12	Cap Nut	1/4-20	2
<input type="checkbox"/>	13	Screw, Hex Washer Head	#6 x 3/8	2
<input type="checkbox"/>	14	Bumpers (set of two)		1
<input type="checkbox"/>	15	Hand Crank		1
<input type="checkbox"/>	16	Clip, Crank Handle		2

NOTES:

1. Uniguard is optional and specified at time of order. Available only with select fabrics, refer to sales literature for availability.
2. Arm assemblies are complete and include upper mounting bracket.

ASSEMBLING THE AWNING

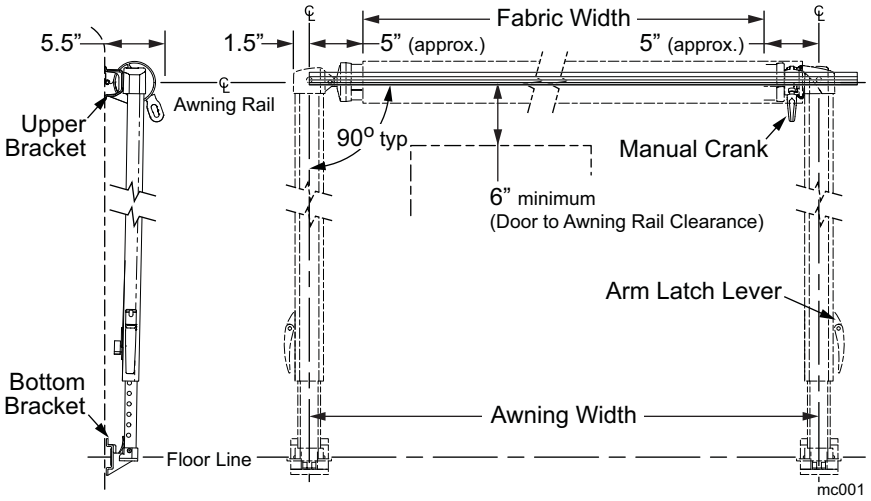

Figure 1. General Layout

ATTACH THE END PLUG ASSEMBLIES TO THE ROLLER TUBE

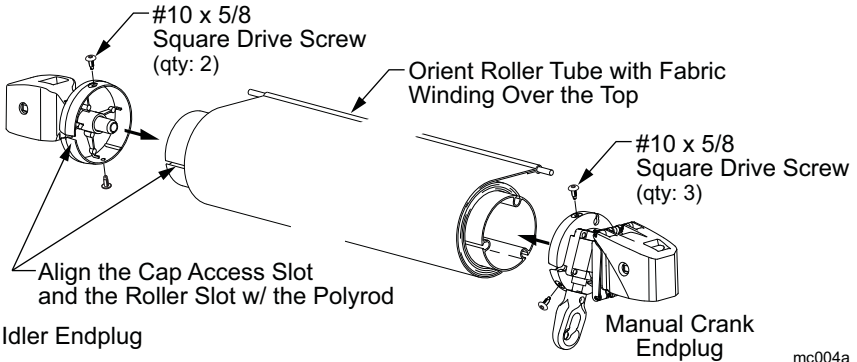

Figure 2. Attaching the End Plugs.

1. Orient the roller tube with the fabric wrapping over the top of the roller tube.
2. On the left end, orient the end cap of the idler end plug with the roller tube. The access slot of the end cap must align with the roller tube slot that has the canopy polyrod.
3. Firmly seat the endcap on the roller tube and attach using two (2) #10 x 5/8 square drive screws.
4. On the right end, firmly seat the endcap of the manual crank end plug onto the roller tube. This endcap has 3 access slots to line up with the slots of the roller tube. Attach the endcap and roller tube using three (3) #10 x 5/8 square drive screws.

ATTACH THE ARMS TO THE END PLUGS

NOTE: Before assembling, layout the arms to determine the latch lever positions. The arms may be arranged with both handles to the outside as shown in Figure 1 or can be swapped so that the handles are inside of the awning.

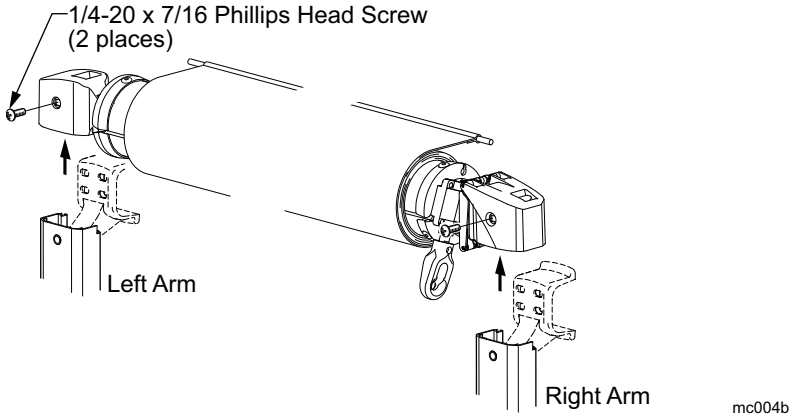

Figure 3. Attaching the Arms.

1. On one side, insert the arm channel into the end plug. Align the hole in the end plug with the threaded hole in the arm.
2. Attach the arm and end plug using one (1) 1/4-20 x 7/16 phillips head screw.
3. Repeat steps 1 and 2 for the other arm.

INSTALLING THE AWNING

MOUNTING THE LOWER BRACKETS

1. On the awning rail, mark the position of the centerlines of the arms. Ensure that the arms will not interfere with any lights, vents or other obtrusions.
2. Using a non-permanent method of marking such as a chalk line, mark a perpendicular line from the awning rail down to the floor line. This is the centerline of the arms.
3. Position and attach the bottom mounting brackets. These should be centered on the lines made in the previous step and must be attached to the structure at the floor line of the vehicle. Attach using 1/4 x 2 1/2 lag screws.

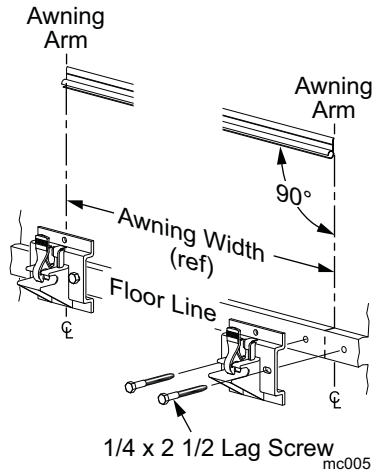

Figure 4. The Bottom Brackets.

NOTE: After starting the screw but before tightening, put silicone sealant around the hole and threads to seal the screw.

MOUNTING THE AWNING

1. Measure the distance from the awning rail to the bottom mounting brackets.
2. On each arm, adjust the arm length so the distance from the center of the roller to the foot is approximately equal to the measurement in step 1.
 - To adjust arm length, open the arm latch and slide the lower channel up or down as required. Close the latch and slide the lower channel until the locking pin clicks into the nearest positioning hole.

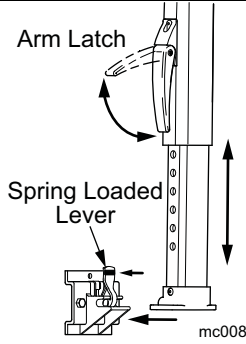
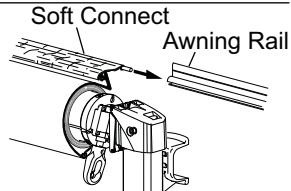
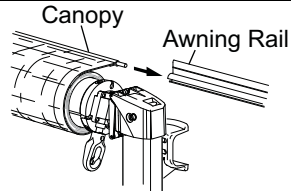

Figure 5. Setting the Arm.

The next step will require two people. One to feed the canopy into the awning rail and hold one arm, the second to hold the second arm while sliding the canopy into position. For longer awnings, a third person may be beneficial.

3. Slide the canopy polyrod into the awning rail. Continue to "walk" the arms and canopy down the rail until the arms are in line with the centerline marks made previously.

Tip: Slightly open one end of the rail, then spray inside the awning rail track with a dry silicone lubricant. This will aid in sliding the fabric into the rail.



Canopy w/ Uniguard mc015

Figure 6. Sliding the Fabric.

4. Lift the bottom of the arm up and secure the foot into the bottom bracket. The foot has a horizontal pin that goes under the spring-loaded lever of the bottom bracket. Repeat for both arms.
5. Use the manual crank and carefully open the awning 12 – 18 inches to provide access to the upper mounting brackets.
6. Loosen the black locking knob on the upper brace.
7. Slide the upper portion of the brace up so that the upper mounting bracket straddles the awning rail.
8. Center the bracket on the arm centerline.
9. Attach the upper bracket using two (2) 1/4 x 3 lag screws. The screws must go into the vehicle structure. The screws can go through the flat portion of the awning rail.

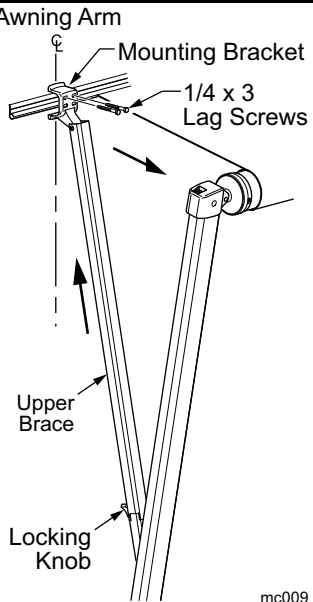

Figure 7. Upper Bracket.

NOTE: After starting the screw but before tightening, put silicone sealant around the hole and threads to seal the screw.

10. Repeat steps 6 through 9 for the other arm.

INSTALLING THE STOP BOLT

1. Retract the awning.
2. Observe if the centerline of the roll bar is level with or slightly higher than the centerline of the awning rail. The bottom of the roll bar must not be higher than the awning rail.
3. Adjust the arm length as required. Open the arm latch and slide the upper channel up or down as required. Close the latch and slide the upper channel until the locking pin clicks into the nearest positioning hole.
4. Mark the position of the stop hole that is directly below the upper channel.
5. From the inside of the channel, insert a 1/4-20 x 7/16 quadrex head screw with a star washer through the hole. Slide the centering spacer over the screw and inside the mounting hole. Secure with a 1/4-20 cap nut.

Tip: It may be necessary to lift the upper channel to tighten the cap nut.

6. Repeat for other arm.

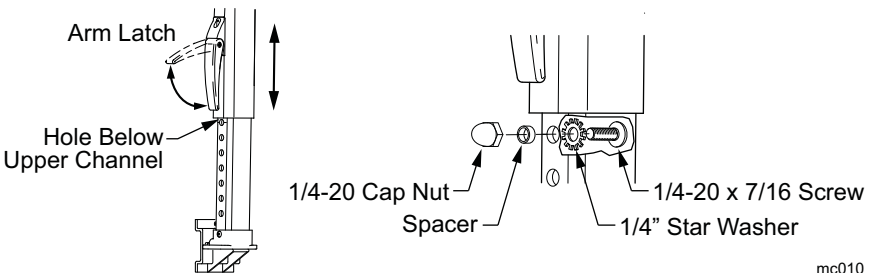

mc010

Figure 8. Installing the Stop Bolt.

INSTALLING THE RUBBER BUMPERS

Because of vibration and movement, it may be necessary to "tighten" the awning arms when stored in the travel position. Two rubber bumpers are provided for this purpose.

1. Open the awning to expose the top of the upper brace.
2. Peel and stick a rubber bumper on the upper brace, opposite the locking knob as shown.
3. Repeat for second arm.

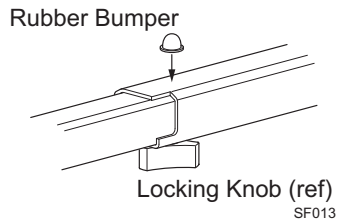

Figure 9. Rubber Bumpers.

SECURING THE FABRIC

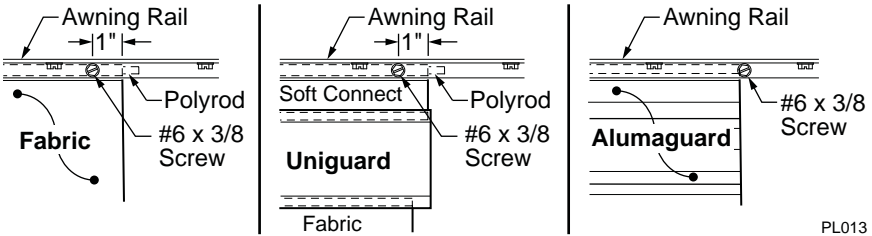

Figure 10. Securing the Fabric.

PL013

1. Roll the awning in and out several times to make sure that the fabric is square on the roller tube.
2. Secure the canopy using one #6 x 3/8" hex head screw on both sides.
 - 2.1 For vinyl awnings, place screw through awning rail, polyrod and canopy approximately 1" in from the end of the fabric.
 - 2.2 For Uniguard awnings, place screw through awning rail, polyrod and the soft connect material approximately 1" in from the end of the fabric.
 - 2.3 For Alumaguard awnings, place screw on the outer edge of the Alumaguard (not through the Alumaguard).

INSTALLING THE TRACTIONERS

The tractioners are used with the Alumaguard and Uniguard metal fabric wraps.

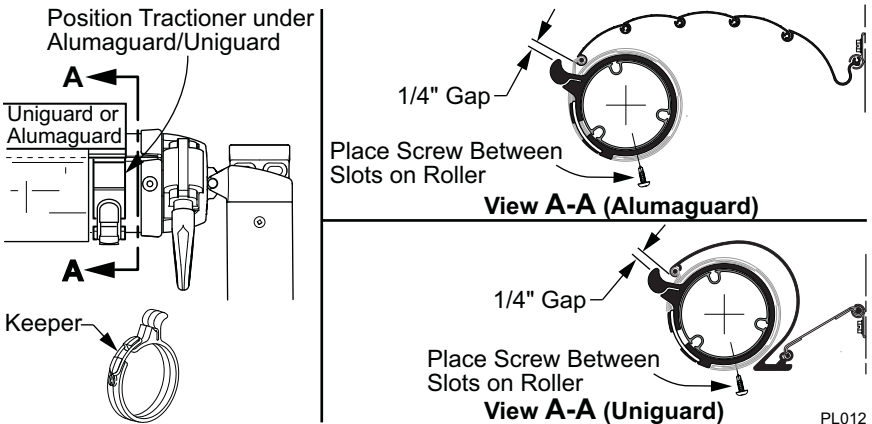

Figure 11. Installing the Tractioners.

PL012

1. Extend the awning until the Alumaguard/Uniguard is extended as shown.
2. Unlock the keeper and wrap the tractioner around the roller tube.
3. On each end of the roller tube, position a tractioner under the Alumaguard/Uniguard with a 1/4" gap between Alumaguard and tractioner. Lock the keeper.
4. Extend the awning to verify that the tractioners are lifting the metal wrap up and over the roller assembly.
5. To secure the tractioner, drill a 1/8" hole through the tractioner and roller tube, roughly center the hole between two slots of the roller tube.
6. Secure each tractioner with one (1) #10 square drive screw.

MANUAL CRANK HANDLE STORAGE CLIPS

Two clips are provided to store the manual crank handle. These may be mounted horizontally or vertically.

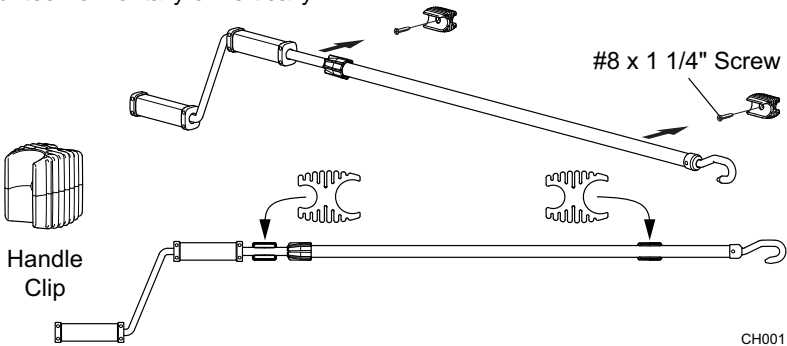

CH001

The clips are designed so that one side has a smaller diameter to fit the smaller tube of the handle. The other side has a larger diameter to fit the larger tube of the handle. The clips can be arranged as shown or the clips can be oriented so both attach to the larger tube (i.e. if the handle is fully collapsed for storage).

1. Snap the clips on to the crank handle.
2. Position the handle in the desired location and mark the locations of the clips.
3. Remove the clips from the crank handle and mount at the marks made previously. Use the #8 x 1 1/4" screws provided.

NOTE: The screws will go through the mounting surface approximately 1/2"; if the mounting surface material is thinner than 1/2" the screws will protrude through the opposite side.

LED SWITCH INSTALLATION (FACTORY OPTION)

These instructions are for the optional factory installed LEDs in the roller tube. For aftermarket LED Upgrades refer to: 052593-001, White LED Upgrade or 052594-001, RGB LED Upgrade.

SPECIFICATIONS

MOUNTING:	LED light strip is factory mounted in a specially designed roller tube. Wire is concealed in canopy hem.
LENGTH:	Available for awnings 10' – 21'* * Maximum LED strip length is 16' 5". Strip is centered in roller tube for units longer than 18'
POWER:	1A, 12VDC
CONTROLS:	Single pole, single throw switch (SR0101) <i>Note: The Switch kit is ordered separately. Kit includes in-line fuse holder and 2A spade type fuse. For an installer furnished control switch, see note under "Switch Installation".</i>

CAUTIONS:

- ⚠ The wire should be secured to the wall of the vehicle where it is exposed on the outside of the vehicle. Use a quality silicone sealant/adhesive.
- ⚠ Do not route the wire over sharp edges or heat sources that can cut or fray the wires or wire insulation.
- ⚠ Damage that is a result of improper routing may void warranty.

WIRE ROUTING, STANDARD

1. Drill a 3/16" hole into the vehicle wall below the right edge of the canopy.
2. Route the wires from the canopy into the vehicle. Allow slack in the wire between the canopy and the wall. Seal the hole and wires with a quality silicone sealant.

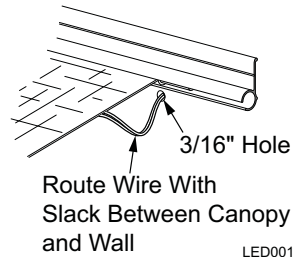

NOTE: There is approximately 8 feet of wire from the wall entry point. Controls should be located within this distance.

SWITCH INSTALLATION

NOTE: Installers may choose to furnish the control switch. The installation requires that the power line (+12VDC) be attached to a dedicated 2A circuit breaker or a 2A in-line fuse must be installed between the switch and power source. Location of the fuse should be close to the switch for easy access.

1. Determine the location of the switch.
2. At the switch location, cut a 1 1/8" x 1 1/2" hole.
3. Wire the switch as shown below. Wire terminals at the switch are .187, 18-24 awg female disconnects.

NOTE: Allow adequate slack in the 12VDC power line so that the in-line fuse (installed in step 4) can be accessed from behind the switch.

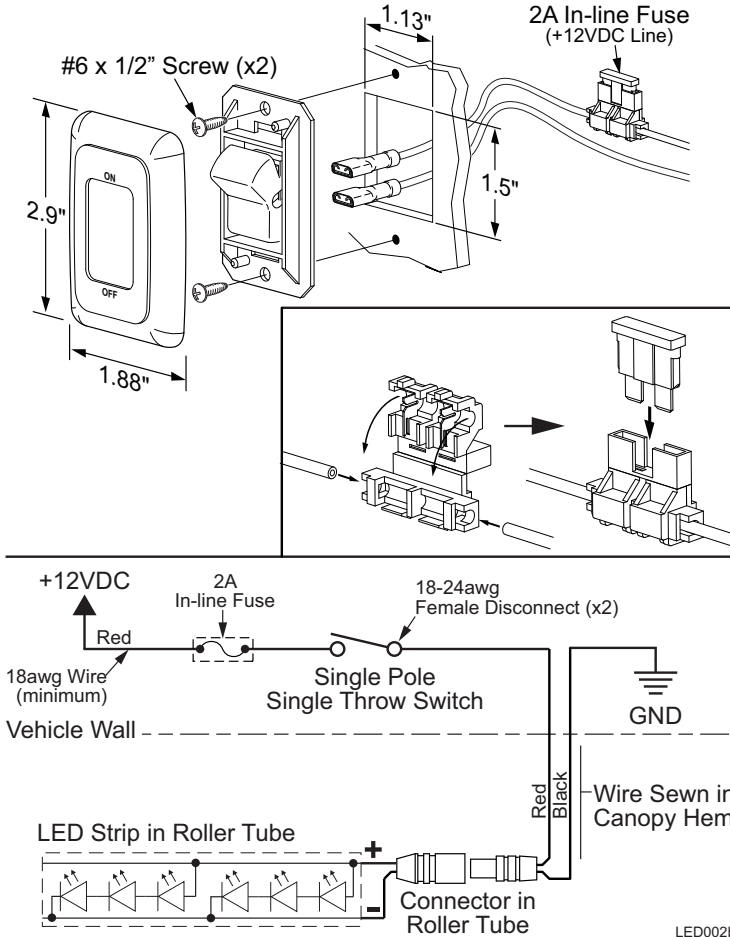

LED002b

4. Install the in-line fuse:
 - 4.1. Near the switch, cut the red 12VDC power line to the switch. Do not strip the insulation.
 - 4.2. Insert a wire end into one of the wire channels until it butts up against the stop.
 - 4.3. Fold that half of the connector body over until the element contacts the wire. Use pliers to crimp the connector closed.
 - 4.4. Repeat for the second wire end.
 - 4.5. Slide the fuse into the fuse port. Ensure that is firmly seated.
5. Press the in-line fuse, wires and switch into the mounting hole. Secure the switch using two (2) #6 x 1/2" screws.
6. Snap the switch bezel over the switch frame.



The Manual Crank Patio Awning is a product of Carefree of Colorado, located in Broomfield, Colorado, USA. The information contained in or disclosed in this document is considered proprietary to Carefree of Colorado. Every effort has been made to ensure that the information presented in the document is accurate and complete. However, Carefree of Colorado assumes no liability for errors or for any damages that result from the use of this document.

The information contained in this manual pertains to the current configuration of the models listed on the title page. Earlier model configurations may differ from the information given. Carefree of Colorado reserves the right to cancel, change, alter or add any parts and assemblies, described in this manual, without prior notice.

Carefree of Colorado agrees to allow the reproduction of this document for use with Carefree of Colorado products only. Any other reproduction or translation of this document in whole or part is strictly prohibited without prior written approval from Carefree of Colorado.

Carefree of Colorado 2145 W. 6th Avenue Broomfield, CO 80020 a **Scott Fetzer** company